

---

---

***Fast, Easy,  
Precision Diagnostics***

---

---

from Ultra-X:

- R.A.C.E.R.** ..... PC, XT, AT, 286 and 386 Hardware/Firmware Diagnostics Card
- R.A.C.E.R. II** ..... PC, XT, AT, 286 and 386 Hardware/Firmware Diagnostics Card with POST Capability
- R.A.C.E.R. Professional** ..... Engineering Level Hardware/Firmware Diagnostics Card with POST Capability
- R.A.C.E.R. PS2** ..... Hardware/Firmware Diagnostics Card for Micro Channel Systems
- QuickTech** ..... PC Diagnostics Software
- QuickPost-PC** ..... Hardware Diagnostics Card for PCs
- QuickPost-PS2** ..... Hardware Diagnostics Card for Micro Channel Systems
- MASM QuickRef** ..... Programmer's Reference Software

*For information on any of these products, call or write:*

**Ultra-X, Inc.**

P.O. Box 730010  
San Jose, CA 95173-0010

Telephone: (408) 988-4721  
FAX: (408) 988-4849

---

---

***R.A.C.E.R. II™***

---

---

***Real-Time AT/XT  
Computer Equipment  
Repair***

---

**User's Guide**

---

**Ultra-X, Inc.**

***Fast, Easy, Precision Diagnostics . . .***

P.O. Box 730010  
San Jose, CA 95173-0010

# **R.A.C.E.R. II<sup>TM</sup>**

*Hardware/Firmware  
Diagnostics Card for Fast  
Component-Level Troubleshooting of  
PC, XT, & AT (286/386/486) Computers*

## **User's Guide**

**Ultra-X, Inc.**

P.O. Box 730010  
San Jose, CA 95173-0010

## Notice

Except as expressly provided by the warranty accompanying this product, R.A.C.E.R. II and the accompanying written material are provided *as is* without warranty of any kind, including the implied warranties of merchantability and fitness for a particular purpose, even if Ultra-X has been advised of that purpose. In no event will Ultra-X be liable for any direct, indirect, consequential or incidental damages arising from the use or inability to use such product even if Ultra-X has been advised of the possibility of such damages. Some states do not allow the exclusion or limitation of implied warranties or liabilities or consequential damages, so the above limitation or exclusion may not apply to you.

Further, Ultra-X, Inc. reserves the right to revise this publication and to make changes from time to time in the contents hereof without obligation of Ultra-X, Inc. to notify any person of each revision or changes.

*Copyright © 1991-1993 Ultra-X, Inc. All rights reserved.*

No part of this manual may be reproduced, copied, adapted, or transmitted in any form or by any means without expressed written permission from Ultra-X, Inc.

Printed in the United States of America.

## Ultra-X, Inc.

**Fast, Easy, Precision Diagnostics . . .**

P.O. Box 730010 ♦ San Jose, CA 95173-0010

Tel: (408) 988-4721

FAX: (408) 988-4849

R.A.C.E.R. II is a trademark of Ultra-X, Inc. IBM, IBM PC, PC/XT, and PC/AT are trademarks of International Business Machines Corporation. Other product names mentioned in this manual are trademarks or registered trademarks of their respective companies and are hereby acknowledged.

# R.A.C.E.R. II™ User's Guide

## Table of Contents

### 1 Introduction

What is R.A.C.E.R. II . . . . .	1-1
Using R.A.C.E.R. II . . . . .	1-2
R.A.C.E.R. II's Features . . . . .	1-3
Commonly Asked Questions about R.A.C.E.R. II . . . . .	1-6
Using this Manual . . . . .	1-8
Technical Support . . . . .	1-9

### 2 Setting R.A.C.E.R. II Switches

R.A.C.E.R. II's Switch Blocks . . . . .	2-1
Selecting the System to be Tested . . . . .	2-3
Selecting Test Modes . . . . .	2-5
Selecting Tests . . . . .	2-7
All Tests, Normal Speed . . . . .	2-7
All Tests, Fast Speed . . . . .	2-8
Selecting One Test, Normal Speed . . . . .	2-8
Selecting One Test, Fast Speed . . . . .	2-10
Printing Test Results to a Printer . . . . .	2-12
Output Test Results to LPT1 . . . . .	2-12
Output Test Results to LPT2 . . . . .	2-13
Special RAM Test Modes (80286 Only) . . . . .	2-14

### 3 Installing and Running R.A.C.E.R. II

System Compatibility . . . . .	3-2
Video Display Compatibility . . . . .	3-3
Installing the R.A.C.E.R. II Board . . . . .	3-5
Starting R.A.C.E.R. II and Conducting Tests . . . . .	3-11
Troubleshooting Start-Up Problems . . . . .	3-16

# R.A.C.E.R. II™

## User's Guide

---

---

### Table of Contents

#### 4 PC and XT Tests

Test Descriptions .....	4-1
Self Test .....	4-1
Test A (Hex: 01) — BIOS Read-Only Memory .....	4-1
Test B (Hex: 02) — 8253 Timer/Counter Chip .....	4-2
Test C (Hex: 03) — 8259 Interrupt Controller .....	4-2
Test D (Hex: 04) — 8237 Direct Memory Access Circuit .....	4-3
Test E (Hex: 05) — Dynamic Memory Refresh .....	4-4
Test F (Hex: 06) — System Dynamic Memory Tests .....	4-5
Test G (Hex: 07) — Dip Switches/8255 Test .....	4-6
Test H (Hex: 08) — Keyboard Circuit 8255 .....	4-7
Test I (Hex: 09) — 8088 Microprocessor .....	4-7
Test J (Hex: 0A) — 8087 Coprocessor .....	4-7
Test K (Hex: 0B) — Speaker Test .....	4-7
Test L (Hex: 0C) — Printer Port 1 .....	4-8
Test M (Hex: 0D) — Printer Port 2 .....	4-8
Test N (Hex: 0E) — Serial Port 1 .....	4-8
Test O (Hex: 0F) — Serial Port 2 .....	4-9
Test P (Hex: 10) — EGA Video Card Test .....	4-9
Test Q (Hex: 11) — Monochrome Video RAM Test .....	4-9
Test R (Hex: 12) — CGA Video RAM Test .....	4-10
Test S (Hex: 13) — Video Character Set Test .....	4-10

# R.A.C.E.R. II™

## User's Guide

---

---

### Table of Contents

#### 5 AT (80286/80386) Tests

Test Descriptions .....	5-1
Self Test .....	5-1
Test A (Hex: 01) — 8254 Timer Circuit .....	5-2
Test B (Hex: 02) — 8237 DMA Controller 1, Channels 0-3 .....	5-2
Test C (Hex: 03) — 8237 DMA Controller 2, Channels 4-7 .....	5-3
Test D (Hex: 04) — Memory Refresh Circuit .....	5-3
Test E (Hex: 05) — 74LS612 DMA Page Register 1 .....	5-4
Test F (Hex: 06) — 74LS612 DMA Page Register 2 (80386 Only) .....	5-4
Test F (Hex: 06) — 8259 Interrupt Controller 1, Channels 0-7 (80286 only) .....	5-4
Test G (Hex: 07) — 8259 Interrupt Controller 1, Channels 0-7 (80386 only) .....	5-4
Test G (Hex: 07) — 8259 Interrupt Controller 2, Channels 8-15 (80286 only) .....	5-5
Test H (Hex: 08) — 8259 Interrupt Controller 2, Channels 8-15 (80386 only) .....	5-5
Test H (Hex: 08) — 8042 Processor (80286 only) .....	5-5
Test I (Hex: 09) — 8042 Processor (80386 only) .....	5-5
Test I (Hex: 09) — Keyboard (80286 only) .....	5-6
Test J (Hex: 0A) — 80287/80387 Coprocessor .....	5-6
Test K (Hex: 0B) — Video Switch Setting .....	5-6

# R.A.C.E.R. II™

## User's Guide

---

### Table of Contents

#### 5 AT (80286/80386) Tests (cont'd)

Test L (Hex: 0C) — 80286/80386 Microprocessor .....	5-6
Test M (Hex: 0D) — System Base RAM (0 - 640K) .....	5-7
Test N (Hex: 0E) — 146818 CMOS Clock .....	5-7
Test O (Hex: 0F) — Serial Port 1 .....	5-8
Test P (Hex: 10) — Serial Port 2 .....	5-8
Test Q (Hex: 11) — Printer Port 1 .....	5-9
Test R (Hex: 12) — Printer Port 2 .....	5-9
Test S (Hex: 13) — EGA Video Card Test .....	5-9
Test T (Hex: 14) — Monochrome Video RAM Test .....	5-10
Test U (Hex: 15) — CGA Video RAM Test .....	5-10
Test V (Hex: 16) — Keyboard Lock .....	5-10
Test W (Hex: 17) — Video Character Set Test .....	5-10

#### 6 Reference

Troubleshooting a Dead System .....	6-1
Troubleshooting PC and XT Computers .....	6-4
Troubleshooting Cross-Reference Table for DTK PIM XT Motherboard .....	6-4
ACER 710 Computer Troubleshooting Reference ..	6-7
PC/XT Advanced Troubleshooting Reference .....	6-8
Troubleshooting AT Computers .....	6-9
High and Low BIOS Placement Reference .....	6-9
Advanced Troubleshooting IBM AT Model 5170-239 Motherboard .....	6-11
Chip Set Cross Reference .....	6-13

# R.A.C.E.R. II™

## User's Guide

---

### Table of Contents

#### 7 System Block Diagrams

IBM PC Clock Circuitry Block Diagram .....	7-2
IBM XT Block Diagram .....	7-3
IBM AT Compatible Block Diagram .....	7-4
IBM AT Compatible Sub-Section Block Diagram .....	7-5
IBM AT Compatible Local and System Bus .....	7-6
IBM AT System Block Diagram .....	7-7
80386 System Block Diagram .....	7-8
Chips & Technologies AT System Block Diagram .....	7-9
VLSI AT System Block Diagram .....	7-10

#### 8 POST Mode

Overview .....	8-1
System Requirements .....	8-4
Running R.A.C.E.R. II in POST Mode .....	8-5
POST Code Reference .....	8-8
AMI BIOS Rev. 2.2x .....	8-9
AMI BIOS Plus .....	8-11
Award 386 BIOS .....	8-15
Chips & Technologies BIOS .....	8-18
Faraday A-TEASE System .....	8-21
IBM AT BIOS .....	8-23
Phoenix BIOS .....	8-26
Tandy 3000 BIOS .....	8-30

# R.A.C.E.R. II

## Technical Notice

---

### Revision 4.xx ROM Enhancements

In response to customer requests for system burn-in capability and easier testing of computers which successfully complete Power On Self Test (POST), Ultra-X, Inc. now offers these and other enhancements in its revision 4.0 and above R.A.C.E.R. II ROM. Highlights of the 4.xx firmware release include:

- ◆ System burn-in capability in 286 and 386 modes for new and repaired computers without removing the system's BIOS ROMs.
- ◆ Enhanced support for 386SX and 486 based systems.
- ◆ Enhanced EGA/VGA video support.

---

### System Burn-In Support

For systems which properly initialize (i.e., those which successfully complete POST), you can now run R.A.C.E.R. diagnostics in 286 or 386 mode **without removing the system's HIGH and LOW BIOS ROMs** and replacing them with the Ultra-X BIOS ROMs. This allows easier testing of systems which boot OK but have other problems (such as a base RAM failure) that you need to isolate, and it also permits R.A.C.E.R. diagnostics to be used for continuous burn-in testing on new or repaired systems. When the system's original BIOS ROMs are not replaced, R.A.C.E.R. II initializes after the computer has properly booted, and then continuously runs its tests until the system is powered off.

All of R.A.C.E.R. II's features and functions remain the same as described in the R.A.C.E.R. II User's Guide — the only difference is that you needn't swap the system's BIOS with the Ultra-X BIOS chips when the 1-4 switch block is set to AT286 or AT386 mode.

For systems which partially boot (i.e., hang during POST) or do not initialize at all, you must still swap the system BIOS ROMs with the Ultra-X BIOS ROMs to run R.A.C.E.R. diagnostics.

### Enhanced 386SX and 486 Support

Additionally, the R.A.C.E.R. II revision 4.xx ROM now offers improved support and CPU identification for 386SX and 486 based systems.

- ◆ To test 386SX based systems, set the R.A.C.E.R. II board to test an AT286 system (i.e., set switch 3 of the 1-4 switch block to ON).
- ◆ To test 486 based systems, set the R.A.C.E.R. II board to test an AT386 system (i.e., set switch 4 of the 1-4 switch block to ON).

Once R.A.C.E.R. II initializes, the type of system being tested will be correctly identified as an 80286, 80386SX, 80386DX, or 80486 on the first screen and on the processor test (test L/hex 0C).

### Enhanced EGA/VGA Video Support

R.A.C.E.R. II now supports *virtually all types* of EGA/VGA video subsystems when used in computers which successfully complete the POST routine (i.e., when the system's original BIOS is not replaced with the Ultra-X BIOS). This means that you no longer have to be concerned with video compatibility when using R.A.C.E.R. II to perform burn-in testing on new or repaired systems, or when using R.A.C.E.R. II to troubleshoot a system which has problems that occur after POST has finished.

Note that EGA/VGA support still requires that you set switches on R.A.C.E.R. II as described in the *R.A.C.E.R. II EGA/VGA Display Support Technical Notice* (dated 01/92); however, the video adapter no longer needs to be 100% IBM compatible. For *dead* systems and computers which fail to successfully complete the POST sequence, then EGA/VGA support is still limited to those adapters which are **100% IBM compatible**, since testing such systems requires that the original BIOS ROMs on the motherboard be swapped with the Ultra-X BIOS ROMs.

## R.A.C.E.R. II Technical Notice

### EGA/VGA Display Support

Due to customer requests, Ultra-X now offers the capability of using R.A.C.E.R. II with 100% IBM compatible EGA/VGA color displays. This notice updates the information provided in the R.A.C.E.R. II User's Guide regarding *Video Display Compatibility*.

#### Dip Switch Settings

To use R.A.C.E.R. II with an EGA or VGA color display, switch settings on the **1-10 Switch Block**, located in upper right corner of the board, should be set as follows:

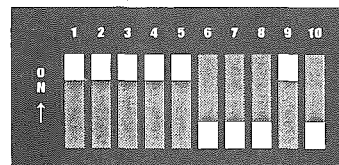

EGA - Normal Speed

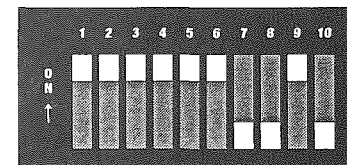

VGA - Normal Speed

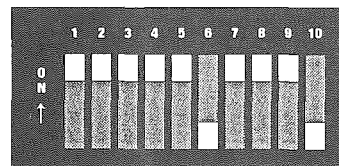

EGA - Fast Speed

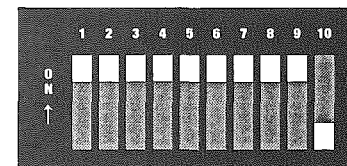

VGA - Fast Speed

When using R.A.C.E.R. II with an EGA or VGA display, please note the following:

- ◆ **Diagnostic Tests:** *All* tests are performed (i.e., you cannot select an individual test when using an EGA/VGA display).
- ◆ **Data Log Option:** Test results are automatically output to LPT2 (i.e., printer port LPT1 is not available for printing test results).

#### EGA/VGA Compatibility

The video must be 100% IBM EGA/VGA compatible *on power-up* (i.e., the video's native mode must be IBM EGA/VGA compatible). R.A.C.E.R. II ignores any switch settings which may be in

effect on the video board, and any display mode changes which may be attempted using software supplied with the video board.

Only EGA/VGA *color* video displays are supported. Compatibility with EGA/VGA monochrome or gray-scale video adapters cannot be ensured.

**Supported EGA Displays** — Virtually all EGA displays have been found to be compatible with R.A.C.E.R. II. If you have problems with an EGA display, follow the troubleshooting guidelines given below.

**Supported VGA Displays** — The following VGA displays have been tested and found to be compatible with R.A.C.E.R. II:

- ◆ IBM VGA
- ◆ Compaq VGA
- ◆ Paradise PVGA1 and PVGA1A
- ◆ Western Digital WD9C00 and WD9C10

Please contact Ultra-X Technical Support for a current listing of compatible VGA video adapters. You can try using VGA displays other than those listed above *without harming R.A.C.E.R. II*, however, VGA displays other than those tested and approved by Ultra-X may not be compatible. If you have problems with a VGA display, follow the troubleshooting guidelines given below.

✚ DISABLE ALL SHALLOW ROM/RAM FIRST

### Troubleshooting EGA/VGA Display Problems

If you use R.A.C.E.R. II with an EGA/VGA display and have problems (e.g., you do not see the R.A.C.E.R. diagnostic screen on power-up, you get a partial or distorted display, etc.), we recommend you try the following:

1. Remove the EGA/VGA video board from the system being tested.
2. Then try running R.A.C.E.R. II.

If R.A.C.E.R. II initializes OK and performs its diagnostic tests (watch the 7-segment Numeric Display for test numbers and the Pass/Fail LEDs), then the EGA/VGA video adapter is not 100% compatible on power-up and cannot be used with R.A.C.E.R. II. Your options are:

- ◆ Run R.A.C.E.R. II without video and use the 7-segment Numeric Display and Pass/Fail LEDs to monitor the tests being performed and the test results.
- ◆ Use a compatible monochrome or CGA video adapter to view R.A.C.E.R. II's diagnostic screens.

If R.A.C.E.R. II fails to initialize after removing the EGA/VGA video adapter, please follow the instructions given under *Troubleshooting Start-Up Problems* in Chapter 3 of the R.A.C.E.R. II User's Guide.

## Chapter 1 Introduction

### What is R.A.C.E.R. II

R.A.C.E.R. II (Real-Time AT/XT Computer Equipment Repair) is a plug-in diagnostic board that allows service technicians, system integrators and developers, and end-users to quickly troubleshoot and isolate component-level failures in IBM PC, XT, AT (80286/80386 CPU) and compatible micro-computers.

Using a combination of hardware and firmware (software), R.A.C.E.R. II can test and help you isolate failed components in systems that have virtually any level of problem, from computers which appear to be completely *dead*, to those which completely fail or partially malfunction during or after power-up and boot.

R.A.C.E.R. II is designed to initialize itself and conduct component-level diagnostics with the *least amount of system support* (i.e., without the operating system and as little of the hardware functioning as possible). Only the power supply, microprocessor, and main data bus must be functioning for R.A.C.E.R. II to initialize and conduct its diagnostics - you don't even need a video card and monitor to follow the diagnostics (although if video is available, R.A.C.E.R. II shows you everything it's doing right on the screen). Thus, with R.A.C.E.R. II you can easily diagnose problems with malfunctioning systems that cannot be isolated by software utilities and other testing methods that require much of the system to be functional and the operating system to be loaded. It will be quickly evident how much time and money R.A.C.E.R. II can save you in making simple component-level repairs.



## Using R.A.C.E.R. II

**Easy to Install** — To use R.A.C.E.R. II, you simply install the board in any available option board slot in the system you wish to test, then power-up the computer. R.A.C.E.R. II *simultaneously* supports both monochrome and CGA video adapters, so if the system is equipped with either or both types of video boards, R.A.C.E.R. II immediately initializes the monitor(s) and then displays a series of screens that allow you to follow the progress of the diagnostics, test by test, and see the results of each test.

**Fault Trees** — If the system fails a test, a fault tree of suspect components is displayed indicating the order in which chips (ICs) should be checked and replaced to correct the problem. If multiple tests fail, you can compare the fault trees displayed to see if there are reoccurring suspect components, thus more easily identifying the chip(s) you should replace first.

**Diagnostics** — The diagnostic routine, which consists of over 20 individual tests for PC and XT computers and over 25 tests for AT (286/386) computers, loops continuously until you turn off the computer. This continuous-loop feature allows you to test systems for long periods of time (overnight or longer if necessary) to isolate intermittent failures which may only surface after extended testing (e.g., RAM failures).

**Data-Log Function** — For extended testing, or whenever you want hard copy of R.A.C.E.R. II diagnostic results, you can enable R.A.C.E.R. II's Data-Log function. When using the Data-Log function, R.A.C.E.R. II outputs its test results to a printer connected to the system's printer port LPT1 or LPT2.

## R.A.C.E.R. II's Features

R.A.C.E.R. II is equipped with several features that give you maximum flexibility in isolating failures:

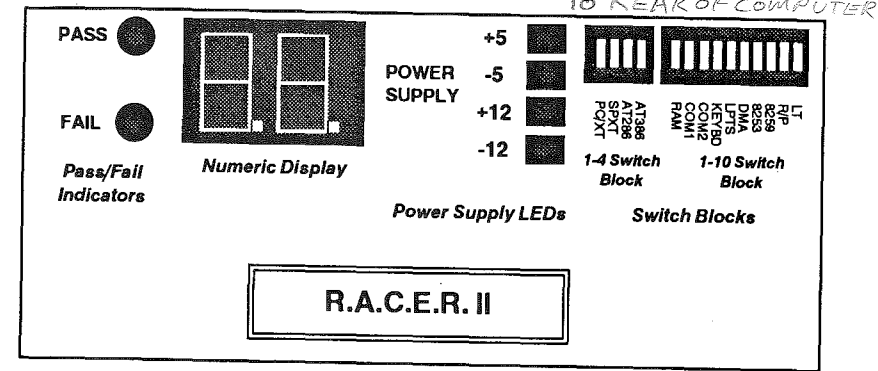

Top Half of R.A.C.E.R. II Board

The above illustration shows the top half of the R.A.C.E.R. II board, and identifies the different components provided on the board to help you with your troubleshooting.

**Switch Blocks** — R.A.C.E.R. II has two switch blocks located in the far upper right corner of the board. The **1-4 switch block** allows you to select the type of computer to be tested. The **1-10 switch block** allows you to select the test mode, the diagnostic tests you wish to run (you can run one individual test of your choice, or all tests), and enable other functions such as the Data-Log function.

**Test Modes** — Two test modes are available: the R.A.C.E.R. component-level diagnostics mode and the POST (Power On Self Test) mode, which is more fully described on the next page. As noted, the diagnostics mode consists of a series of tests which are looped continuously, with individual test results and fault trees listing suspect components appearing right on the screen in front of you. R.A.C.E.R. II even allows you to select the speed at which diagnostics are executed: tests can either be run at normal

speed which gives you time to completely review all information and fault trees displayed during the diagnostic routine, or, once you're familiar with R.A.C.E.R.'s diagnostics, you can run tests at fast speed to complete your troubleshooting in less time.

**POST Mode** — The other mode R.A.C.E.R. II provides allows you to monitor Power On Self Test routines output by the system BIOS in 80286, 80386, or 80486 based systems. The POST mode compliments R.A.C.E.R. II's powerful component-level diagnostics by allowing you to utilize a system's own internal Power On Self Test routine to quickly identify potential problem areas.

Using the POST mode can sometimes make it easier to troubleshoot and isolate component failures in conjunction with the component-level diagnostics mode. For example, using R.A.C.E.R. II in the POST mode first may quickly identify a problem area in general, then running the diagnostics will identify the specific component(s) that have failed. In some instances, if the failure POST identifies is readily obvious, it can even eliminate the need to use R.A.C.E.R. II's diagnostics at all.

**Numeric Display** — A 7-segment numeric display is provided to assist you in identifying R.A.C.E.R. II's component-level diagnostic tests, and individual tests conducted by the system BIOS when using R.A.C.E.R. II in the POST mode.

When viewing R.A.C.E.R. II's diagnostic displays, each test is identified on the screen by a letter (A - S for PC/XT tests and A - W for AT tests). As the diagnostic routine is executed, each test is also identified on the numeric display in hexadecimal notation (e.g., Test A = 01 hex, Test J = 0A hex, etc.).



If the system being tested doesn't have video capability for some reason, or the video subsystem is malfunctioning (i.e., R.A.C.E.R. II cannot initialize the video), you can still easily monitor R.A.C.E.R.'s diagnostics, test by test, by simply watching the codes which appear on the numeric display as each test is conducted.

When R.A.C.E.R. II is run in the POST mode, each POST code (test code) output during the Power On Self Test routine is also identified on the numeric display in hexadecimal notation. Since much of the POST routine is conducted prior to video initialization, using R.A.C.E.R. II's numeric display is the only way of identifying individual POST codes when R.A.C.E.R. II is run in the POST mode.

**Pass/Fail Indicators** — R.A.C.E.R. II is also equipped with visual pass/fail indicators which are located to the left of the numeric display. These green and red LEDs can also help you when you're testing a computer that either doesn't have video for some reason, or has a malfunctioning video subsystem. As each component-level diagnostic test is completed, one of the pass/fail LEDs lights up: green if the test passes, or red if the test fails.

**Power Supply LEDs** — Located between the switch blocks and the numeric display are the four power supply LEDs. These LEDs light up when R.A.C.E.R. II is initialized, thereby indicating that the system's power supply is functioning properly. If these LEDs do not light up when the computer is turned on, or they flicker after the system is powered-up, it may mean there's a problem with the computer's power supply.

---

## Commonly Asked Questions about R.A.C.E.R. II

*I currently own and use IBM's Advanced Diagnostic diskette. How does R.A.C.E.R. II differ? What makes it better?*

- ◆ Because R.A.C.E.R. II is connected directly to the system, it can diagnose most boards even if they do not initialize properly. In contrast, the IBM Advanced Diagnostic Diskette **requires the system to be about 97% functioning** in order to boot itself properly and run.

*I'm a Manager in charge of many PCs. How can I benefit from R.A.C.E.R. II and what else will I need?*

- ◆ R.A.C.E.R. II can help you quickly determine whether your problem is due to a software or hardware malfunction. In many cases, such as a parity check error, anyone should be able to isolate the defective chip and replace it.
- ◆ R.A.C.E.R. II is a small board that can easily fit into a repair kit or briefcase and be carried on-site for rapid troubleshooting and problem isolation. It is also recommended that a disk drive diagnostic program (such as **QuickTech** from Ultra-X) and the necessary hand tools (screwdrivers, IC extractor, etc.) be carried as well. Users may also wish to purchase additional spare RAM chips as they are most likely to fail and are easy to change (spare RAM chips can also be supplied by Ultra-X).

*As a technician, I often come across many system boards that show no indication of functioning at all. In these cases, the motherboard is simply replaced. How is R.A.C.E.R. II useful in these situations?*

- ◆ Basically, you have what we call a **dead PC**. During actual field tests of R.A.C.E.R. II, it has been found

that, in over 60 percent of cases, the dead PC problem results from a defect in one of the RAM chips in bank zero. With R.A.C.E.R. II, video is initialized first and then the diagnostic tests are displayed and run, so the defective RAM chip is simply shown on a memory error map and can then be easily located and replaced.

*Other diagnostic instruments have been called to my attention. Many of these devices cost upwards of \$5000 and require extensive knowledge and support. Why is R.A.C.E.R. II better?*

- ◆ R.A.C.E.R. II is available to both end-users and experienced PC service technicians **at about one-tenth the price of other hardware/firmware diagnostic products**; and it can diagnose most system problems as well and easier than the higher-priced products.
- ◆ The R.A.C.E.R. II hardware and firmware contains diagnostic code which is executed immediately upon power-up. This is the key to R.A.C.E.R. II's effectiveness.
- ◆ R.A.C.E.R. II's diagnostic code has been designed to perform *in even the most difficult situations*. For example, even with all RAM, ROM, the 8237 DMA, the 8255 PPI, the 8259 Interrupt controller, the 8253 Timer, and many other chips removed or damaged, R.A.C.E.R. II will still initialize both a monochrome and CGA display simultaneously, perform its diagnostic tests, and relay useful information about the system under test.
- ◆ Many diskette-based diagnostic programs are also available ranging from \$250 to \$700. However, these programs require a system to be nearly 100% functional (i.e., POST must be completed successfully, video initialized, and the operating system loaded), whereas R.A.C.E.R. II can **successfully troubleshoot computers that are up to 95% dead**.

## Using this Manual

This manual fully describes all of R.A.C.E.R. II's features and functions, and contains reference materials and advanced troubleshooting techniques to help you isolate virtually any type of component-level failure.

- ◆ Chapter 2 contains information on using the two switch blocks to select the type of computer to be tested, and select the test mode, diagnostic tests, and other functions you want to use to troubleshoot the computer.
- ◆ Chapter 3 contains instructions on installing the board in a system you wish to test and running the component-level diagnostic routine.
- ◆ Chapters 4 and 5 provide information on each of the individual tests R.A.C.E.R. II performs when testing a PC or XT computer (Chapter 4) or an AT computer (Chapter 5).
- ◆ Chapter 6 contains a variety of reference materials you can use to help you perform more advanced troubleshooting on systems which present particularly difficult problems.
- ◆ Chapter 7 contains system block diagrams for IBM and compatible PC, XT, and AT (80286/80386) computers which you can use to help you locate various components/circuits which R.A.C.E.R. II identifies as having failed one or more diagnostic tests.
- ◆ Chapter 8 contains complete information on using R.A.C.E.R. II's POST mode to monitor test codes output during the Power On Self Test sequence in 80286, 80386, and 80486 computers. This chapter includes extensive POST code listings for most popular BIOS products including Phoenix, AMI, Award, and IBM so you can easily identify the components/circuits being tested during the POST routine.

## Technical Support

Ultra-X is committed to helping you successfully use the R.A.C.E.R. II diagnostic board to troubleshoot and isolate component-level failures in IBM and compatible microcomputers.

If you have a question about or problem with R.A.C.E.R. II, or would like information on any of our other precision PC diagnostic products, please give us a call. We'll be glad to help!

Our Technical Support phone and FAX numbers are:

Technical Support:	(408) 988-4721
FAX:	(408) 988-4849

## Chapter 2

# Setting R.A.C.E.R. II Switches

---

---

This chapter contains information on R.A.C.E.R. II's switch blocks which are used to:

- ◆ Specify the type of microcomputer you wish to test (PC, XT, special XT, or AT).
- ◆ Set up R.A.C.E.R. II to run in either the diagnostics mode or in the POST (Power On Self Test) mode.
- ◆ Select the component-level test(s) you wish to run, if R.A.C.E.R. II is set to run in the diagnostics mode.

Information on installing and running R.A.C.E.R. II to perform component-level diagnostics is provided in Chapter 3 of this manual.

---

### R.A.C.E.R. II's Switch Blocks

R.A.C.E.R. II has two switch blocks which are located in upper right corner of the board. The following illustration identifies the two switch blocks, one of which has 4 switches, and the other 10 switches.

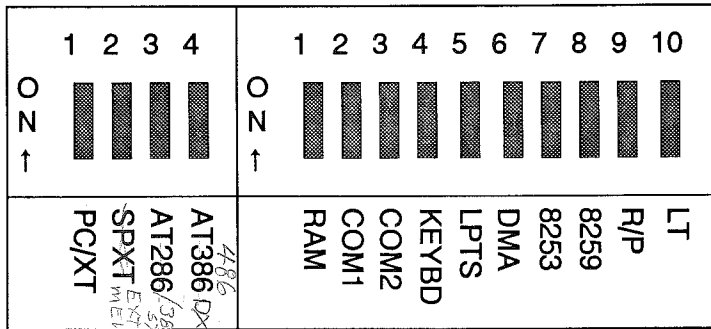

1-4 Switch Block

1-10 Switch Block

- ◆ The switch block with 4 switches is referred to as the **1-4 switch block**. This switch block is located just to the right of the four power supply LEDs, and it is used to select the type of computer you wish to test with R.A.C.E.R. II's component-level diagnostics.
- ◆ The switch block with 10 switches is referred to as the **1-10 switch block**. This switch block is located in the upper right-most corner of the board. The 1-10 switch block is used to set the board to run in the diagnostics mode or the POST (Power On Self Test) mode (switch 9), to conduct a Lamp test to check R.A.C.E.R. II's numeric display (switch 10), and to select the component-level tests you want to run when the board is used in the diagnostics mode (switches 1 - 8).

## Selecting the System to be Tested

The **1-4 switch block**, located just to the right of the four power supply LEDs, is used to select the type of computer you wish to troubleshoot with R.A.C.E.R. II's component-level diagnostics.

The type of computer you wish to test *must* be selected when **the computer is off** (i.e., before power is applied). To select the type of computer to be tested, set **one, and only one**, of the four switches on the 1-4 switch block to the ↑ON (upper) position:

**Switch 1 (PC/XT)** – Setting switch 1 to the ↑ON position specifies that the computer to be tested is an IBM or compatible PC or XT.

**Switch 2 (SPXT)** – Setting switch 2 to the ↑ON position specifies that the computer to be tested is a special XT clone.

SEE TECH. NOTES

From 2 to 5% of recent XT type computers, especially those using VLSI chip sets, have system board designs that are more like ATs than XTs. The design of these systems is such that the motherboard reads the system BIOS first *before* initializing the buses (option board slots). Consequently, the bus connector where R.A.C.E.R. II is installed is not initialized on power-up, so R.A.C.E.R. II fails to start. To solve this problem, the system BIOS ROMs on the motherboard must be replaced with special R.A.C.E.R. XT BIOS ROMs so that R.A.C.E.R. II can be initialized on power-up.

If R.A.C.E.R. II fails to initialize an XT clone you are testing, contact Ultra-X Technical Support for information on obtaining the special XT BIOS ROMs required to test these types of systems (see *Technical Support* in Chapter 1 for information on contacting Ultra-X). The firmware required to test special XTs is provided in the R.A.C.E.R. II EPROMs, and different EPROMs are *not* required.

<sup>386SX</sup>  
Switch 3 (AT286) — Setting switch 3 to the ↑ON position specifies that the computer to be tested is an IBM AT or compatible computer equipped with an 80286 microprocessor.

<sup>486</sup>  
Switch 4 (AT386) — Setting switch 4 to the ↑ON position specifies that the computer to be tested is an IBM AT or compatible computer equipped with an 80386<sup>DX</sup> microprocessor.  
<sup>OR 486</sup>

#### NOTE

When R.A.C.E.R. II is in the diagnostics mode, make sure that **one, and only one**, of the switches on the 1-4 switch block is set to the ↑ON position.

**POST Mode** — When running R.A.C.E.R. II in the POST mode, the switch settings on the 1-4 switch block have no effect.

## Selecting Test Modes

The 1-10 switch block, located in the upper right-most corner of the R.A.C.E.R. II board, is used to select various test modes and diagnostic tests you want to run. This section describes the different test modes you can select. The next section describes how to set the switches to run different component-level tests when using R.A.C.E.R. II in the diagnostics mode.

**Switch 10 (Lamp Test)** — Switch 10 enables and disables the Lamp Test function which is used to check the 7-segment numeric display located between the power supply and pass/fail LEDs.

If you suspect that the numeric display may not be functioning properly, set switch 10 to the ↑ON position and then power up the computer. Once R.A.C.E.R. II is initialized, the numeric display should show eighty-eight (88), indicating that it is functioning properly. If 88 is not displayed, there may be a problem with the numeric display.

When switch 10 is set to ↑ON, no other R.A.C.E.R. II functions are available. Unless you specifically wish to check the numeric display, switch 10 should be left in the ↓OFF position at all times.

**Switch 9 (Diagnostics or POST Mode)** — Switch 9 is used to set R.A.C.E.R. II to run in the component-level diagnostics mode or in the Power On Self Test (POST) mode.

To activate the diagnostics mode, which allows you to perform component-level troubleshooting, set switch 9 to the ↑ON (R) position. When switch 9 is in the ↑ON (R) position, all of R.A.C.E.R. II's component-level diagnostic tests are available to be run.

When switch 9 is set to the **↓OFF (P)** position, the POST mode is activated. The POST mode allows R.A.C.E.R. II to monitor Power On Self Test codes output by the system BIOS to port 80h during the POST routine which occurs prior to system boot. POST codes are output by virtually all 80286, 80386, and 80486 computers, and some PC/XT-class computers.

When switch 9 is set to the **↓OFF (P)** position, R.A.C.E.R. II simply acts as a POST diagnostic tool, and no component-level diagnostic functions are available. Complete information on using R.A.C.E.R. II's POST mode is provided in Chapter 8 of this manual.

**Switches 7 & 8 (Normal or Fast Speed)** — Switches 7 and 8 control the speed at which component-level diagnostics are executed. Normal (slow) speed allows you to review R.A.C.E.R. II's screens, test results, and diagnostic fault trees at a relatively slow pace. Fast speed executes the tests very quickly. Once you're familiar with R.A.C.E.R. II's functions, you'll probably want to run the diagnostics at fast speed most of the time.

- ◆ **Fast Speed** — To run diagnostics at fast speed, set *both* switches 7 and 8 to the **↑ON** position.
- ◆ **Normal Speed** — When *either* switch 7 or 8 is set to the **↓OFF** position, R.A.C.E.R. II runs its diagnostics at normal (slow) speed.

## Selecting Tests

Selecting the tests you wish to perform with R.A.C.E.R. II involves setting some or all of switches 1 through 8 on the **1-10 switch block**. You can set up R.A.C.E.R. II to run all of its tests at either normal or fast speed, or you can select one particular test you want to run at either normal or fast speed.

If all tests are selected, the entire diagnostic routine is repeated continuously until you decide to stop testing. Likewise, if one test is selected, that test is executed continuously until you decide to stop it. This continuous test loop feature allows you to perform extensive troubleshooting and burn-in testing to isolate intermittent failures which may not reveal themselves on one or just a few passes of R.A.C.E.R. II's diagnostics.

### NOTE

Note that all of the switch setting illustrations in the rest of this chapter refer to the **1-10 switch block**. Since only switches 1 - 8 on that switch block are used to select tests, we've only shown those eight switches in the pictures.

### All Tests, Normal Speed

(SEE TECH. NOTE ON EGA/VGA DISPLAY SUPPORT)

When switches 1 - 8 are all set to the **↓OFF** position, R.A.C.E.R. II runs *all* component-level diagnostic tests, and runs them at *normal speed*.

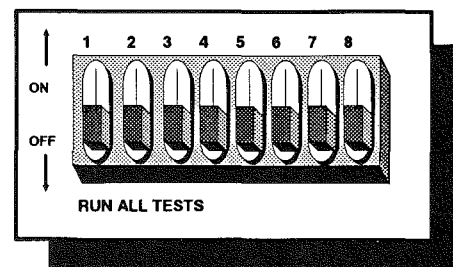

Run All Tests, Normal Speed



## All Tests, Fast Speed

When switches 1 - 6 are set to the ↓OFF position and switches 7 and 8 are set to the ↑ON position, R.A.C.E.R. II runs *all* diagnostic tests and executes them at *fast speed*.

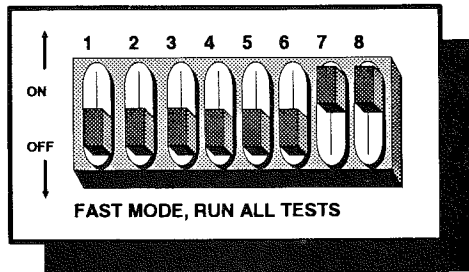

*Run All Tests, Fast Speed*

## Selecting One Test, Normal Speed

When running at normal speed, some of R.A.C.E.R. II's diagnostic tests can be selected individually. When only one test is selected, the test runs continuously until you decide to stop it.

To select and run one test at normal speed, refer to the switch settings on the following page for the test you wish to execute.

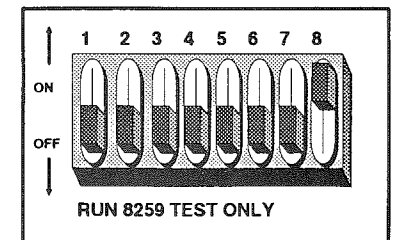
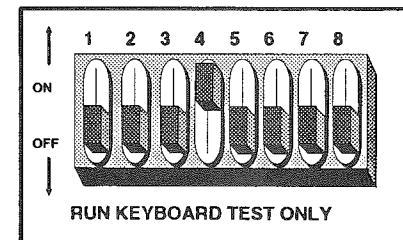
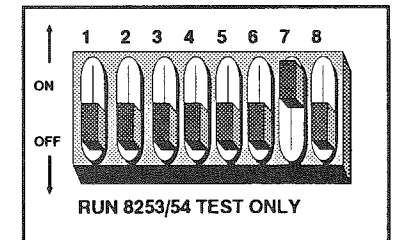
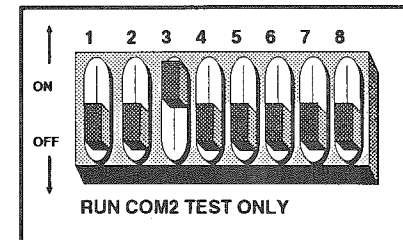
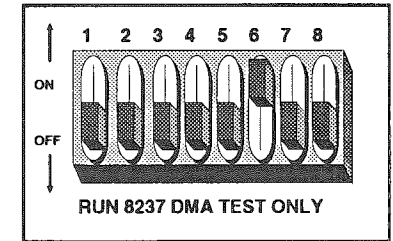
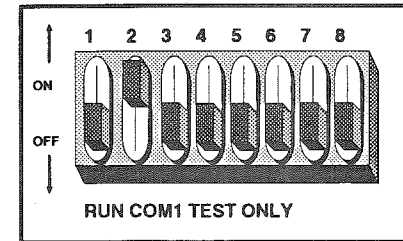
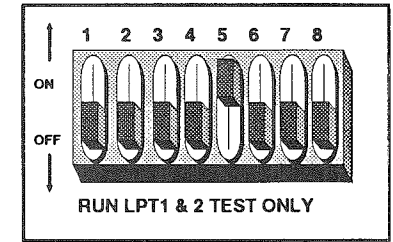
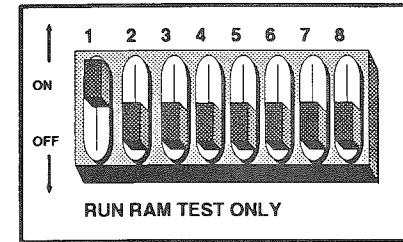

*Run Individual Tests, Normal Speed*

## Selecting One Test, Fast Speed

When running at fast speed, some of R.A.C.E.R. II's diagnostic tests can be selected individually. As in normal speed, a single test run at fast speed is executed continuously until you decide to stop it.

### NOTE

The 8253 and 8259 tests cannot be selected individually at fast speed, since *both* switches 7 and 8 must be in the **↑ON** position to enable fast speed. To run the 8253 or 8259 test individually, you must use the normal speed setting.

To select and run one test at fast speed, refer to the switch settings on the following page for the test you wish to execute. Remember, if you want to run the 8253 or 8259 test only, you must use the normal speed setting (see the previous section in this chapter).

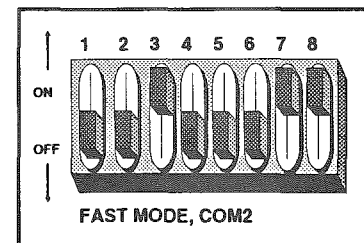
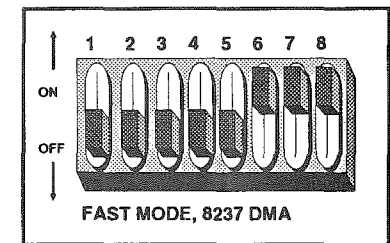
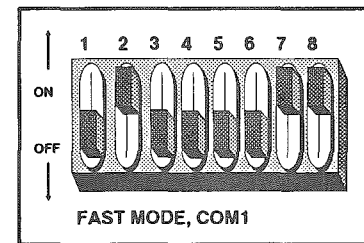
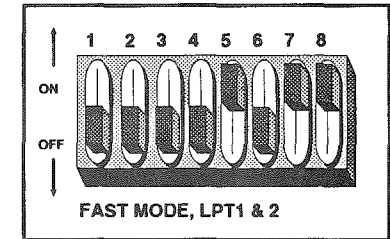
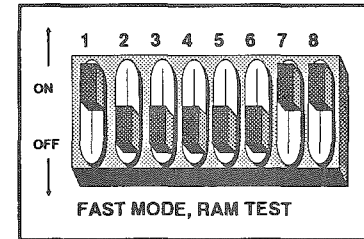
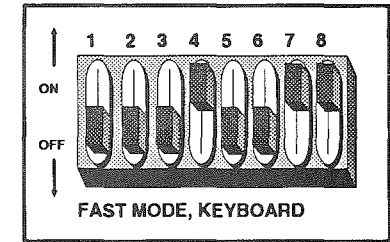
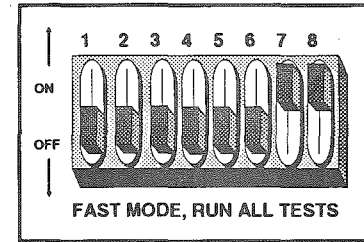

*Run Individual Tests, Fast Speed*

## Printing Test Results to a Printer

R.A.C.E.R. II has a **Data Log** option which allows you to output print-screens of test results to a printer connected to one of the computer's parallel ports. Either parallel port LPT1 or LPT2 can be used, depending on the parallel ports available on the computer being tested.

When the Data Log option is enabled, R.A.C.E.R. II outputs a print-screen at the end of each test cycle if a printer is connected to the specified parallel port, and the selected port is operating properly.

### NOTE

Since R.A.C.E.R. II's display uses the full IBM character set, the printer connected to the test system should be set to print the standard IBM character set. If the printer does not have the capability to print the standard IBM character set, then some of the print-outs will not exactly match the R.A.C.E.R. II display shown on the monitor.

## Output Test Results to LPT1

On the **1-10** switch block, set switches 1 and 2 to the **↑ON** position to output test results to LPT1.

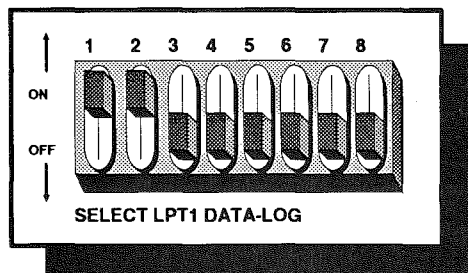

Switch Settings to Output Test Results to LPT1

Switches 3 - 8 can be set as you wish:

- All tests, normal speed = 3 - 8 ↓OFF
- All tests, fast speed = 3 - 6 ↓OFF, 7 & 8 ↑ON
- One test, normal speed = **One** of switches 3 - 8 ↑ON **only**; RAM and COM1 tests cannot be run individually.
- One test, fast speed = 7 & 8 ↑ON; **one** of switches 3 - 6 ↑ON **only**; RAM, COM1, 8253, and 8259 tests cannot be run individually.

## Output Test Results to LPT2

On the **1-10** switch block, set switches 1, 2 and 3 to the **↑ON** position to output test results to LPT2.

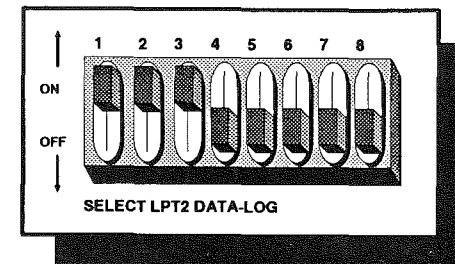

Switch Settings to Output Test Results to LPT2

Switches 4 - 8 can be set as you wish:

- All tests, normal speed = 4 - 8 ↓OFF
- All tests, fast speed = 4 - 6 ↓OFF, 7 & 8 ↑ON
- One test, normal speed = **One** of switches 4 - 8 ↑ON **only**; RAM, COM1, and COM2 tests cannot be run individually.
- One test, fast speed = 7 & 8 ↑ON; **one** of switches 4 - 6 ↑ON **only**; RAM, COM1, COM2, 8253, and 8259 tests cannot be run individually.

## Special RAM Test Modes (80286 Only)

Early IBM ATs (80286 CPUs *only*) were equipped with 256K or 512K of base RAM (memory) on the system board. Since R.A.C.E.R. II's RAM test is designed to check for and test 640K of RAM, the RAM test will fail when testing these types of computers since 640K of RAM is not present.

To accommodate these early 80286 ATs with 256K or 512K of RAM, the following switch settings can be used to run all of R.A.C.E.R. II's tests and check only 256K or only 512K of base memory:

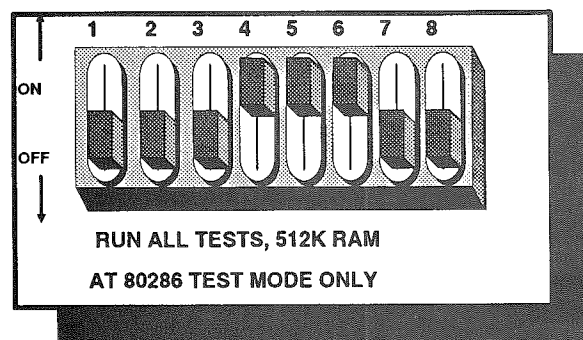
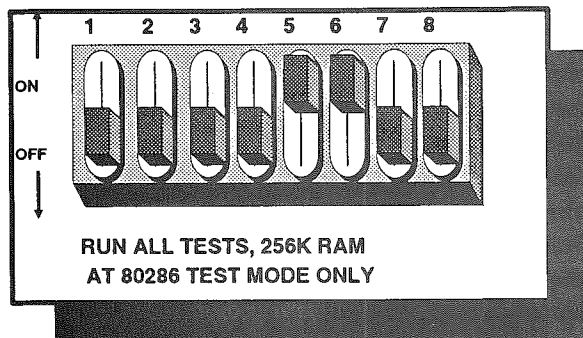

## Chapter 3 Installing and Running R.A.C.E.R. II

This chapter contains information and procedures for installing R.A.C.E.R. II in a computer you wish to troubleshoot, and running R.A.C.E.R. II's component-level diagnostics. Sections contained in this chapter include:

**System Compatibility** — This section provides information on the types of computers that can be tested using the R.A.C.E.R. diagnostic mode.

**Video Display Compatibility** — This section provides information on the types of video adapters that can be used to view R.A.C.E.R. II's diagnostic displays.

**Installing the R.A.C.E.R. II Board** — This section contains instructions for installing R.A.C.E.R. II in a computer you wish to test.

**Starting R.A.C.E.R. II and Conducting Tests** — This section provides details on initializing R.A.C.E.R. II and using the board's numeric display and other indicators to monitor diagnostics and other aspects of the system being tested.

**Troubleshooting Start-Up Problems** — This section contains information on what to check if R.A.C.E.R. II does not initialize after the computer is powered up, or the diagnostic displays do not appear on the system's monitor after initialization.

## System Compatibility

R.A.C.E.R. II's diagnostics mode can be used to perform component-level troubleshooting on the following types of microcomputers:

- ◆ IBM PC, XT, and compatibles.
- ◆ Special XTs which R.A.C.E.R. II fails to initialize.

From 2 to 5% of recent XT type computers, especially those using VLSI chip sets, have system board designs which are more like ATs than XTs. The design of these systems is such that special XT BIOS ROMs must be installed on the system board to replace the system BIOS chips so that R.A.C.E.R. II can initialize on power-up.

If R.A.C.E.R. II fails to initialize an XT clone you're attempting to troubleshoot, contact Ultra-X Technical Support for information on obtaining the special XT BIOS ROMs required to test these types of systems (see *Technical Support* in Chapter 1 for information on contacting Ultra-X). R.A.C.E.R. II's EPROM chips contain the firmware required to test special XTs - different EPROMs are *not* required, only special XT BIOS ROM chips.

- ◆ IBM AT and compatibles (80286 or 80386 microprocessor).

### NOTE

R.A.C.E.R. II can also be used to test PC or XT computers equipped with 8088, 8086, 80188, 80186 or V20 microprocessors.

## Video Display Compatibility

R.A.C.E.R. II is designed to simultaneously support the following video displays:

- ◆ Standard IBM monochrome video adapter or compatible.
- ◆ Standard IBM CGA video adapter or compatible.

R.A.C.E.R. II supports both of the above video adapters *simultaneously*, meaning that either one, or both, of the above types of video cards may be installed in the system to be tested. If two video adapters are present, R.A.C.E.R. II will initialize both when the system is powered up.

### NOTE

Some IBM compatible monochrome adapters do not fully adhere to IBM specifications. If the system being tested uses an IBM compatible monochrome video card, and you see a blinking cursor displayed in the upper left corner of the screen after the system is powered up, instead of R.A.C.E.R. II's diagnostic display, it indicates that R.A.C.E.R. II cannot initialize the video. If this occurs when using an IBM compatible monochrome adapter, swap the video card with another video adapter that is *fully* compatible with IBM monochrome or CGA specifications.

EGA and VGA Video Cards — R.A.C.E.R. II does not support EGA or VGA video adapters, and will not output test results on either type of display.

Both EGA and VGA video displays require more of a system to be functional than monochrome or CGA video adapters. Since R.A.C.E.R. II's logic is designed to begin diagnostics

SEE TECH,  
NOTE ON EGA/VGA  
DISPLAY  
SUPPORT

at the lowest possible level after power-up, supporting EGA and VGA video specifications would prevent some tests from being performed that are otherwise possible when only monochrome and CGA adapters are supported.

R.A.C.E.R. II does, however, perform an EGA Video BIOS test as part of its diagnostics (if an EGA card is installed in the system being tested), but it will not attempt to use an EGA card to display its test results.

**No R.A.C.E.R. II Screen on Power-Up** – If R.A.C.E.R. II's diagnostic display does not appear on the monitor after installing R.A.C.E.R. II and powering up the test system, refer to the section *Troubleshooting Start-Up Problems* at the end of this chapter.

## Installing the R.A.C.E.R. II Board

To install R.A.C.E.R. II in a system you wish to test, perform the following steps.

### NOTE

Step 5 in the following procedure is applicable only when installing R.A.C.E.R. II in special XT computers or AT (80286/80386) computers. This step involves replacing the system BIOS ROMs on the motherboard with special XT or AT BIOS ROMs supplied by Ultra-X. The BIOS ROMs required to test AT computers are included in the R.A.C.E.R. II kit. The BIOS ROMs used to test special XT computers which R.A.C.E.R. II fails to initialize must be requested from Ultra-X (contact Ultra-X Technical Support - see Chapter 1 for instructions and phone numbers).

1. **Tools Required** – To install R.A.C.E.R. II, you need a small flathead and/or Phillips screwdriver depending on the type of screws used on the computer case and expansion slot covers.
2. **Remove Computer Case** – Turn the computer off, and disconnect *all* cables from the rear of the computer. Remove the computer case by following the instructions in the documentation provided with the computer.
3. **Set R.A.C.E.R. II Switches** – Set the switches on the 1-4 and 1-10 switch blocks:
  - ◆ Set *one*, and *only one*, switch on the 1-4 switch block to select the type of computer to be tested. Refer to *Selecting the System to be Tested* in Chapter 2 for instructions on using the 1-4 switch block to specify the type of computer to be tested when using the component-level diagnostics mode.

- ◆ Set switch 9 on the 1-10 switch block to the ↑ON (R) position to activate R.A.C.E.R. II's diagnostics mode. Make sure switch 10 is in the ↓OFF position. Set switches 1 - 8 as you wish to select the test(s) to be performed, normal or fast speed, and to enable data-logging to LPT1 or LPT2 if desired. Refer to *Selecting Tests* and *Printing Test Results to a Printer* in Chapter 2 for instructions on using the 1-10 switch block to select the tests to be executed, and to optionally output test results to a printer.

4. Install R.A.C.E.R. II – Pick an available expansion board slot in which you wish to install R.A.C.E.R. II.

#### NOTE

The more room between R.A.C.E.R. II and any other option boards that may be installed in the system, the easier it will be to change switch settings and view the pass/fail indicators, numeric display, and power supply LEDs on the R.A.C.E.R. II board. You may wish to remove other option boards installed in the computer to make it easier to view R.A.C.E.R. II's indicators and numeric display, and to change settings on the two switch blocks should you wish to do so.

Remove the expansion slot cover attached to the rear of the computer. Holding the upper left and right corners of the R.A.C.E.R. board, *with the component side of the board facing you*, insert R.A.C.E.R. into the expansion slot.

Make sure you insert R.A.C.E.R. II correctly:

- ◆ Hold R.A.C.E.R. II so that the component side of the board is facing you. The 1-4 and 1-10 switch blocks should be in the upper right-most corner of the board.

- ◆ Insert the board into the expansion slot so that the 1-4 and 1-10 switch blocks in the upper right corner are *nearest the BACK of the computer*.
- ◆ Be sure that the gold *fingers* on the bottom of the board are firmly and evenly seated into the bus connector (a gentle rocking motion may be required to properly seat R.A.C.E.R. II in the expansion slot).

#### CAUTION!

Before powering up the system, make sure R.A.C.E.R. II is installed correctly (i.e., with the 1-4 and 1-10 switch blocks in the upper right corner of the board *nearest the BACK of the computer*). If the two switch blocks are nearest the FRONT of the computer, *R.A.C.E.R. II installed backwards*, and applying power to the system with the card installed that way could *destroy the board!*

5. Special XT and AT (286/386) Systems Only – This step applies *only* to setting up R.A.C.E.R. II to run diagnostics on AT (286/386 CPUs) systems and special XT systems which R.A.C.E.R. II fails to initialize. If you're testing a PC or normal XT computer, skip this step and proceed to step 6.
  - ◆ Locate the system BIOS ROM chips on the system board (refer to the motherboard and/or computer manufacturer's technical documentation if necessary).
  - ◆ The AT BIOS chips used to test 80286 and 80386 computers are supplied in the R.A.C.E.R. II kit. The special XT BIOS chips used to test newer XT clones which R.A.C.E.R. II fails to initialize must be requested from Ultra-X.
  - ◆ Locate the *notch* on the AT BIOS or special XT BIOS chips. Orientate R.A.C.E.R. II's BIOS chips with the *notch in the same direction* as the system's BIOS chips.

### CAUTION!

*Permanent damage* will result to R.A.C.E.R. II's AT BIOS or special XT BIOS chips *if the chips are oriented incorrectly in the IC socket* (i.e., if the notch on R.A.C.E.R. II's BIOS chips is not oriented in the same direction as the notch on the system BIOS chips).

R.A.C.E.R. II AT BIOS or special XT BIOS chips which are damaged as the result of incorrect installation are NOT covered by warranty. Contact Ultra-X Technical Support if you are unsure of the proper way to install R.A.C.E.R. II's AT BIOS or special XT BIOS chips on the computer's motherboard, or you need additional R.A.C.E.R. II BIOS chips.

- ◆ Place a small piece of tape on each of the system BIOS chips, then note the following on each chip: 1) the correct orientation of the chip and 2) which IC socket the chip belongs in. This will help you easily return the system BIOS ROMs to their original placement when you're through testing.
- ◆ Using an IC extraction tool, carefully remove the system BIOS ROM chips from the motherboard. *Place the system BIOS ROMs in an anti-static bag* (or other suitable anti-static storage container) for safe keeping while performing diagnostics with R.A.C.E.R. II.
- ◆ Carefully insert R.A.C.E.R. II's AT BIOS or special XT BIOS chips in the empty IC sockets from which the system BIOS ROMs were removed. Make sure that no pins are bent on R.A.C.E.R. II's BIOS chips.

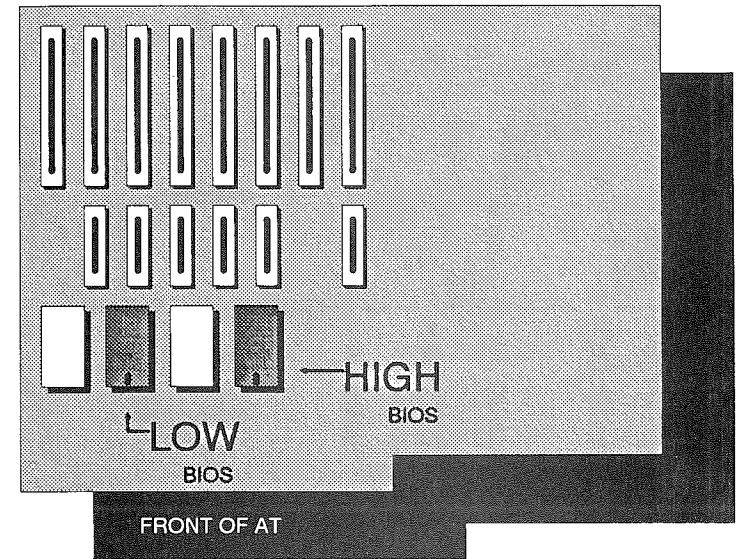

Installing R.A.C.E.R. II's BIOS Chips on System Board

- ◆ Make sure the notch on the R.A.C.E.R. BIOS ROMs is oriented in the same direction as the system BIOS you just removed! Powering up the test system with the R.A.C.E.R. BIOS chips oriented incorrectly can destroy the chips (which is *not* covered by warranty).
- ◆ Note that the HIGH BIOS and LOW BIOS can be reversed (i.e., the HIGH chip can be in the LOW socket or vice versa) *without damaging the chips* (as long as the chips are oriented correctly). But, if the BIOS chips are not in the correct sockets, R.A.C.E.R. II will not initialize. If you are unsure which of the system BIOS ROMs is the HIGH BIOS and which is the LOW BIOS, refer to the section *High and Low BIOS Placement Reference* in Chapter 6 for help in identifying different system BIOS chips.
- ◆ If you have R.A.C.E.R. II's BIOS chips oriented correctly in the IC sockets, but R.A.C.E.R. II fails to



initialize, try swapping (reversing) the BIOS ROMs from one socket to the other (i.e., you probably have the HIGH BIOS in the LOW socket and vice versa). Just remember that the *orientation of the chips in the sockets* is **CRITICAL**. Having the HIGH and LOW BIOS chips *reversed* won't hurt anything, it'll just prevent R.A.C.E.R. II from working.

6. **Reconnect Peripherals** – Reconnect the power cable, video cable(s), and any other cables for peripheral equipment as you wish.

Leave the computer case off during testing. This will allow you to view the pass/fail indicators, numeric display, and power supply LEDs during testing, and will give you easy access to the failed components R.A.C.E.R. II identifies during testing.

7. **Check the Installation** – **STOP HERE** and check the installation:

- ◆ Make sure R.A.C.E.R. II is installed correctly, with the 1-4 and 1-10 switch blocks in the upper right corner of the board *nearest the BACK of the computer*. If the two switch blocks are nearest the FRONT of the computer, *R.A.C.E.R. II installed backwards*, and applying power to the system with the card installed that way could *destroy the board!*

- ◆ If testing an AT (286/386 CPU) or special XT computer, make sure the R.A.C.E.R. BIOS chips are *oriented correctly in the IC sockets* (see step 5). Any damage caused to R.A.C.E.R. BIOS chips due to incorrect orientation in the IC socket is **NOT** covered by warranty!

8. **Start Testing System** – Refer to the next section for information on running diagnostics on the computer to be tested.

## Starting R.A.C.E.R. II and Conducting Tests

1. **Power up the Computer** – After you have installed R.A.C.E.R. II and checked the installation, turn the computer on.
2. **Internal Self Test** – Once power is applied, R.A.C.E.R. II goes through an internal self test. If the self test passes, R.A.C.E.R. II emits an audible beep signaling that it is initialized properly, and, after a brief delay to allow for video start-up, you should see the R.A.C.E.R. II diagnostic display on the monitor.
3. **Diagnostic Displays** – Immediately after R.A.C.E.R. II initializes, it begins testing the computer. The diagnostic display appearing on the monitor identifies the test(s) R.A.C.E.R. II is performing, and the type of system being tested is identified in the lower right corner of the screen. When testing a PC or XT computer, R.A.C.E.R. II displays a series of two screens; when testing an AT computer (286/386 CPU), a series of three screens is displayed.

The following sample screens show what the first and second screens look like when testing an AT-80286 computer. In these examples, the diagnostic routine has completed 9 loops, and the 10th test loop is in progress. As the diagnostic routine is continuously executed, R.A.C.E.R. II keeps a running count on the number of times each test has been run, and shows the total number of times each test has been executed in the PASS and FAIL columns to the right of each test's title.

In screen 1, the 8237 DMA Channels 4-7 test (Test C) has just failed for the 10th time (notice the 0010 in the FAIL column), and the fault tree showing the suspect circuits to check to correct the problem is displayed on the right side of the screen.

= R.A.C.E.R. =

(c) COPYRIGHT 1987-1991 By ULTRA-X, INC.

**AT-80286 Rev. 1.309**

Technical Support (408) 988-4721

TEST IN PROGRESS-Screen 1	PASS	FAIL	SUSPECT CIRCUITS
A 8254 Timer Circuit	0010	P	1 8237 DMA chip
B 8237 DMA Channels 0-3	0010	P	2 8237 Chip select circuit
<b>C 8237 DMA Channels 4-7</b>		<b>0010 F</b>	3 8237 Clock circuit
D Memory Refresh Circuit	0009	P	4 Aux DATA Bus
E 74LS612 DMA Page Reg.	0009	P	5 Aux ADDRESS Bus
F 8259 Interrupts 0-7		0009 F	6 Aux IORD, IOWE
G 8259 Interrupts 8-15	0009	P	7 Main DATA Bus
H 8042 Processor Test	0009	P	8 Main ADDRESS Bus
I Keyboard Test	0009	P	9 82288 system controller
J 80287 Math Processor	0009	P	
K Video Switch Setting	= COLOR =		

*Sample Screen 1 - AT-80286 Tests*

- R.A.C.E.R. -										640 Kbytes RAM										- R.A.C.E.R. -									
LOW Byte					0 1 2 3 4 5 6 7 P					HIGH Byte					8 9 A B C D E F P														
0-128K					.....					0-128K					.....														
128-256K					.....					128-256K					.....														
256-384K					.....■.....					256-384K					.....														
384-512K					.....■.....					384-512K					.....														
512-640K					.....					512-640K					.....														

TEST IN PROGRESS-Screen 2	PASS	FAIL	This test verifies the
L 80286 Processor	0010	P	system RAM.
<b>M System Base RAM</b>	<b>0009</b>	<b>0001 F</b>	If all other tests pass and this test fails (ie: Box=Fail) then suspect only the system RAM.
N 146818 CMOS Clock		0009 F	
O Serial Port 1	0009	P	
P Serial Port 2	0009	P	
Q Printer Port 1		0009 F	
R Printer Port 2	0009	P	
S EGA Video BIOS Test	0009	P	
T MONO Video RAM Test	0009	P	
U CGA Video RAM Test		0009 F	
V System Keyboard LOCK	UN-LOCKED		

*Sample Screen 2 - AT-80286 Tests*

Screen 2 shows the System Base RAM test (test M) which has just failed for the first time on the 10th loop (notice the 0009 in the PASS column, the 0001 in the FAIL column, and the F indicating that the test failed on this loop in the right-most column). The highlighted blocks appearing in the RAM map at the top of Screen 2 indicate that bit 5 of the LOW Byte from 256K - 512K failed on the 10th test loop.

4. **Identifying Tests** – Individual tests are identified on the diagnostic displays with letters, and on the 7-segment numeric display in hexadecimal notation.

◆ Tests executed when testing PC and XT computers are identified on the diagnostic displays with the letters A through S. For detailed descriptions of the tests executed for PC and XT computers, refer to Chapter 4.

◆ Tests executed when testing AT computers are identified on the diagnostic displays with the letters A through W. For detailed descriptions of the tests executed for AT computers, refer to Chapter 5.

5. **Monitoring Tests** – Tests are conducted sequentially, and the current test in progress at any given time is highlighted on the screen. Some tests take longer than others, so don't be surprised if a particular test remains highlighted for awhile.

In the right-most column after the PASS and FAIL columns, R.A.C.E.R. II identifies whether a test has passed (P) or failed (F) on the current test loop. For example, for test M on the second screen shown on the previous page, the 0009 in the PASS column and the 0001 in the FAIL column indicate that the test has been completed 10 times, while the F in the right-most column indicates that the test just failed for the first time on the 10th loop.

The results of each test can also be monitored by viewing the green and red pass/fail indicators (LEDs) which are located to the left of the numeric display (green=pass, red=fail).

6. **Stopping Diagnostics** – The diagnostic routine is looped *continuously* (either all tests, or the one specific test you've selected) until you decide to stop testing. **Whenever you want to stop R.A.C.E.R. II's diagnostics, simply turn off the computer.**
7. **Diagnostic Fault Trees** – R.A.C.E.R. II includes diagnostic fault trees to help you isolate problem components. If the system fails a R.A.C.E.R. II test, these fault trees appear in the lower right window of the display (as shown in *Sample Screen 1 - AT-80286 Tests* earlier). The fault trees list the order in which chips should be checked and replaced to correct the problem identified.

If the system fails more than one test, all fault trees displayed should be compared for reoccurring (matching) chip failures, and those chips which fail multiple tests should be replaced first. In general, it is also advisable (and easier) to replace *socketed chips* before attempting to replace soldered chips. For further information on troubleshooting failures identified by R.A.C.E.R. II's diagnostics, refer to Chapter 6.

When replacing components, you may wish to have the following tools/parts available:

- ◆ An IC extraction tool
- ◆ Screwdrivers, various types
- ◆ 18W to 40W soldering iron
- ◆ Solder sucker
- ◆ Extra Intel 8000 series chips
- ◆ Extra RAM chips - various speeds



8. **Numeric Display** – R.A.C.E.R. II's 7-segment numeric display, located near the center at the top of the board, identifies each test conducted during diagnostics. Tests are identified in hexadecimal notation (for example, 01 = test A, 0A = test J, 0E = test N, 13 = test S, etc.). If the system being tested has no video, or the video is inoperative to begin with or malfunctions during testing, each of R.A.C.E.R. II's tests can still be easily identified by watching the numeric display as tests are performed.
9. **Pass/Fail Indicators** – Directly to the left of the numeric display are green and red LEDs which are R.A.C.E.R. II's visual pass/fail indicators. If the computer being tested has no video, or the video is inoperative to begin with or malfunctions during testing, you can still see the results of each test by watching these LEDs. If a test passes, the green light comes on; if a test fails, the red light comes on.
10. **Power Supply LEDs** – Located between the numeric display and the 1-4 switch block are R.A.C.E.R. II's four power supply LEDs. These LEDs indicate whether or not the power supply is functioning properly. The four power supply LEDs should light up, and remain steadily illuminated, once the computer is powered up and R.A.C.E.R. II is initialized. If they do not light up, or they light up and then flicker, there may be a problem with the power supply. Refer to *Troubleshooting a Dead System* in Chapter 6 for further information if you suspect a problem exists with the system's power supply.

## Troubleshooting Start-Up Problems

If R.A.C.E.R. II fails to initialize, no diagnostic displays appear on the monitor, or the numeric display does not light up when power is applied to the system being tested, check the following information before you call Ultra-X Technical Support:

**R.A.C.E.R. II Fails to Initialize** — If R.A.C.E.R. II fails to initialize when the system is powered up, check the following:

- ◆ Make sure the power cable is attached to the computer and is plugged into the wall outlet. If the fan is not running, the power cable may be loose or not connected at all, or there may be a power short on the system board.
- ◆ Some critical cable within the computer, such as the cabling from the power supply to the system board, may not be connected or may be connected incorrectly. Check all critical cables, contacts, and wiring within the computer.
- ◆ The system's power supply may be faulty (check the power supply LEDs). If you suspect a power supply problem, try swapping power supplies to see if that corrects the problem.
- ◆ Make sure that R.A.C.E.R. II is firmly and correctly installed in the expansion slot (**make sure the 1-4 and 1-10 switch blocks are closest to the BACK of the computer**; if they're nearest the FRONT of the computer, R.A.C.E.R. II is installed backwards and this could *destroy the board!*).
- ◆ Try installing R.A.C.E.R. II in a different bus connector to see if that resolves the problem (the problem could be a bad connector).

- ◆ If you're testing an AT (286/386 CPU) or special XT computer, make sure you've replaced the system BIOS chips on the motherboard with the AT BIOS or special XT BIOS chips required by R.A.C.E.R. II.

Make sure that R.A.C.E.R. II's BIOS chips are **oriented correctly**; and, in the event you *reversed* the HIGH and LOW BIOS, try swapping the BIOS chips from one socket to the other (refer to step 5 in the *Installing the R.A.C.E.R. II Board* section of this chapter for details).

If you're not sure whether R.A.C.E.R. II's BIOS chips are functioning properly or not, install R.A.C.E.R. II and its BIOS chips in a **known good system** - this will allow you to verify that the AT BIOS or special XT BIOS chips are functioning properly.

- ◆ Finally, install and run R.A.C.E.R. II in a **known good system** to make sure that there isn't a problem with R.A.C.E.R. II itself. If R.A.C.E.R. II is OK, then you may be dealing with one or more of three possible failures which are so severe that even R.A.C.E.R. II cannot initialize: the microprocessor is dead, the main data bus is dead, or the DMA hold request to the CPU is activated. Refer to *Troubleshooting a Dead System* in Chapter 6 for details on how to proceed with these problems.

**Video Problems** — If R.A.C.E.R. II initializes (you hear the beep after power-up), but no diagnostic display appears on the monitor, check the following:

- ◆ Make sure the monitor is plugged in and turned on, the contrast and brightness are set to mid-range, and that the video cable between the monitor and the video board is connected properly.

- ◆ If the system you're testing uses an IBM compatible monochrome video adapter, the video card may not fully adhere to IBM specifications, and thus cannot be supported by R.A.C.E.R. II. Swap the video card with another video adapter you know is working properly and is fully compatible with IBM monochrome or CGA specifications.
- ◆ If that doesn't work, try installing the video board in a different bus connector (i.e., a bad connector might be the problem).
- ◆ If the above checks do not resolve the problem, the video subsystem may be faulty. Even without video, you can still monitor R.A.C.E.R. II's diagnostics by watching the numeric display and pass/fail indicators.

**Numeric Display Problems** – If the numeric display does not light up, run the **Lamp Test** (switch 10 ↑ON) to see if the numeric display is faulty (refer to *Selecting Test Modes* in Chapter 2 for details).

## Chapter 4

### PC and XT Tests

---

---

This chapter describes the tests R.A.C.E.R. II executes when you run component-level diagnostics on an IBM PC, XT, or compatible computer.

---

#### Test Descriptions

In the following descriptions, each test's title includes the letter used to identify the test on R.A.C.E.R. II's diagnostic displays, and the corresponding hexadecimal number used to identify the test on the numeric display.

##### Self Test

The first test R.A.C.E.R. II performs is a Self Test. This test insures that R.A.C.E.R. II's hardware and firmware is operating properly. If this test passes, you will hear an audible beep indicating that R.A.C.E.R. II has properly initialized.

##### Test A (Hex: 01) – BIOS Read-Only Memory

The BIOS (Basic Input/Output System) ROM contains the information that the CPU first executes when the system is powered up. It is an 8K ROM located at FE000-FFFFFF which is at the top of the 8088's 1 megabyte memory map. This memory contains the POST (Power On Self Test), I/O drivers, and the diskette bootstrap loader, and as such is very critical to the PC's operation. The contents of this ROM are documented in the *IBM Technical Reference Manual*. In this test, all bytes (8192) are logically summed and the results checked. Note that a BIOS which does not adhere to IBM specifications may fail this test.

## Test B (Hex: 02) — 8253 Timer/Counter Chip

During this test, R.A.C.E.R. II loads a count into each of the three timer channels and then verifies that each channel counts down at a proper pace (not too fast or too slow).

In the PC's design, channel 0 of the 8253 is implemented as a general purpose timer providing a constant time base for the time-of-day clock. It is tied directly to the 8259 Interrupt Controller's channel 0 and cycled 18.2 times a second (54.936 millisecond resolution).

*Channel 1, which is the most important of the three,* is cycled every 15.12 microseconds. It is tied to the DMA Channel 0 which is used in the dynamic memory refreshing scheme to ensure that a full refresh cycle is initiated at least once every 2 milliseconds.

Channel 2 is the last channel used in the PC/XT design. Parts of the 8255 PPI (Parallel Peripheral Interface) chip must be functioning during this test since it is directly tied to the input gate of the 8253's channel 2. If the 8255 is functional, the rest of the test will proceed as above. This channel is used to generate a sine wave which is routed to the speaker. Unlike channels 0 and 1, channel 2 is not as critical to the PC's operation. This channel is used to produce audio signals.

## Test C (Hex: 03) — 8259 Interrupt Controller

R.A.C.E.R. II verifies the operation of the 8259 Interrupt Controller during this test. All eight channels of the 8259 are checked for stuck, false, or missing interrupts.

The 8259 interrupt controller is used by the PC to prioritize up to eight system hardware interrupt requests and then send a master interrupt to the 8088 CPU. The PC uses channel 0 for a

real-time clock update. Channel 1 of the 8259 is used by the keyboard whenever a key is typed. Channel 6 is used by the floppy disk drive.

## Test D (Hex: 04) — 8237 Direct Memory Access Circuit

This test checks all registers and status ports of the 8237 DMA Controller.

The 8237 DMA controller chip is very critical to the PC's operation. It contains four separate channels which allow I/O devices to have direct access to the PC's system RAM for high speed data transfers without using the 8088 microprocessor. Once programmed, the DMA controller can signal the 8088 processor to leave the bus temporarily so that it may complete the actual data transfer by itself at high speeds. The 8237 DMA controller can actually address and transfer only up to 64K bytes at a time so additional circuitry is added in the PC's design to accommodate the extra address lines needed to access the entire 1 megabyte of memory.

DMA channel 0 is the most important in the PC's design, as it is used to accomplish the dynamic memory refresh cycles. Because the PC utilizes dynamic RAM memory, a full refresh cycle must be performed at least once every 2 milliseconds. If these cycles are not completed in time, data in memory can be corrupted. Other DMA channels in the 8237 chip are used for other important tasks such as hard/floppy drive controllers, networking hardware, and any other high speed I/O device.

## Test E (Hex: 05) — Dynamic Memory Refresh

Dynamic Memory Refresh (DMR) is an event that must be employed at least once every 2 milliseconds in order to retain valid data in the system RAM. For DMR to function properly, the following must work:

- ◆ 8237 DMA Controller, which actually does the refresh using its DMA channel 0.
- ◆ 8253 timer channel 1 which issues a refresh request every 15.12 microseconds.

During tests B and D, the 8237 DMA controller and the 8253 timer/counter are initialized to perform the refresh function. A pattern of data is then written to RAM and, after a delay of 2 seconds, the pattern is checked for data integrity. If tests B or D fail, it indicates DMR is not being performed.

## Test F (Hex: 06) — System Dynamic Memory Tests

During this test, R.A.C.E.R. II checks the validity of the system RAM. The entire system memory map (0 - 640K) is tested, regardless of whether all memory is installed or not, since in many cases failure of the 8255 PPI (Parallel Peripheral Interface) or other chips will render the system configuration switch information useless in determining the total amount of actual memory.

The first four banks are tested 16K bytes at a time, and the remaining memory in 64K byte intervals to accommodate both 64K and 256K system boards.

Pass/fail messages and a bit map are graphically displayed to facilitate the location of any memory failure. All eight data bits and the parity bit are checked, and any errors are displayed as a highlighted block on the memory map. The parity bit is generated with every memory write cycle and stored in the ninth bit. When reading memory, the parity bit is checked and a *parity check* error is signaled if it is not the same as when written. Failure of any of the eight data bits will always cause the parity bit to also fail, so any error in the data bits should be resolved first.

As mentioned above, 640K of RAM is tested whether that amount is installed or not. Therefore, failure of an entire bank can mean that it is not installed or that it is completely malfunctioning. This test can easily be used to diagnose any expansion board except that the orientation of the memory banks may differ from board to board. You may have to consult your memory board manual or use trial and error to locate the proper bank/bit orientation.

## Test G (Hex: 07) — Dip Switches/8255 Test

This is the first test of the 8255 PPI (Parallel Peripheral Interface) chip. The 8255 consists of three eight-bit parallel interface ports.

- ◆ Port A is used in two modes. First, it is used to link the keyboards serial-parallel converter to the system bus. In its other mode, port A is used to read in system configuration switch 1 which specifies the number of drives, type of display, etc.
- ◆ Port B is an output only port. All eight bits are used to perform functions such as parity enable/disable, keyboard reset/clear, and 8253 timer 2 gate on/off.
- ◆ Port C is utilized as an input only port. The lower four bits of port C are used to read system configuration switch 2. The upper bits are used to signal whether I/O channel check or parity check has occurred.

This test checks all ports of the 8255. The system configuration switches, *as reported by the 8255*, are shown on the right side of R.A.C.E.R. II's display. If the settings of the configuration switches shown on R.A.C.E.R. II's display do not match the actual settings of the system configuration switches in the computer, the 8255 is malfunctioning. 8255 failures can cause such symptoms as keyboard errors, speaker noises, wrong system configurations, parity errors, and even a *dead PC*.

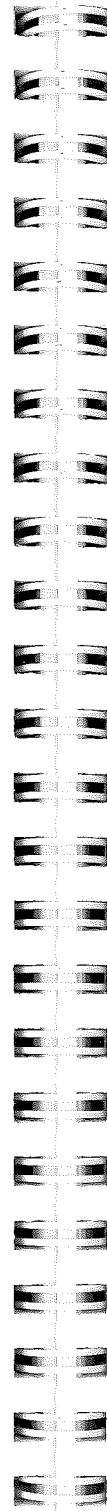

## Test H (Hex: 08) — Keyboard Circuit 8255

R.A.C.E.R. II tests the system's keyboard circuit contained on the motherboard, and if a keyboard is connected to the system, R.A.C.E.R. II verifies that there are no *hot* (broken) keys.

The PC uses a 74LS322 shift register and channel A of the 8255 as the interface for the keyboard. When a key is pressed, the keyboard circuit issues an interrupt request to channel 1 of the 8259 Interrupt Controller.

If this test fails and a keyboard is connected, try another keyboard. If R.A.C.E.R. still detects a failure and Test G (8255 PIO) passed, suspect the 74LS322.

## Test I (Hex: 09) — 8088 Microprocessor

This test checks the control, address, data, and flag registers of the PC and PC/XT's CPU.

## Test J (Hex: 0A) — 8087 Coprocessor

This test checks the system's math coprocessor if one is detected. R.A.C.E.R. II does not attempt to test 100% of the 8087; but if this test passes, the chances are high that the 8087 is fully functional. R.A.C.E.R. II also checks the operational interface between the 8088 and the 8087.

## Test K (Hex: 0B) — Speaker Test

This test verifies the operation of the speaker port and its support circuitry. *This test does not have a pass or fail indication*; the user must verify the proper functioning of the speaker subsystem by listening for audible results.



### Test L (Hex: 0C) — Printer Port 1

During this test, R.A.C.E.R. II looks for LPT1 at a base address of 3BC H. If LPT1 is detected, R.A.C.E.R. II reads and writes printer port 1's DATA and STATUS ports by performing an internal loop-back test.

### Test M (Hex: 0D) — Printer Port 2

During this test, R.A.C.E.R. II looks for LPT2 at a base address of 378 H. If LPT2 is detected, R.A.C.E.R. II reads and writes printer port 2's DATA and STATUS ports by performing an internal loop-back test.

#### NOTE

If more than one printer port is installed at the same address, the test will give invalid results.

### Test N (Hex: 0E) — Serial Port 1

During this test, R.A.C.E.R. II looks for serial port 1 (COM1) at a base address of 3F8 H. If COM1 is detected, its operation is checked using two methods. First, R.A.C.E.R. II tests the 8250 UART chip on the serial card by performing an internal loop-back. If this test passes, then an external loop-back test using R.A.C.E.R. II's special serial test plug is conducted. Note that you must connect the external loop-back connector supplied with R.A.C.E.R. II to COM1 in order for the second part of this test to be performed successfully.

### Test O (Hex: 0F) — Serial Port 2

During this test, R.A.C.E.R. II looks for serial port 2 (COM2) at a base address of 2F8 H. If COM2 is detected, its operation is checked using two methods. First, R.A.C.E.R. tests the 8250 UART chip on the serial card by performing an internal loop-back. If this test passes, then an external loop-back test using R.A.C.E.R. II's special serial test plug is conducted. Note that you must connect the external loop-back connector supplied with R.A.C.E.R. II to COM2 in order for the second part of this test to be performed successfully.

#### NOTE

If more than one serial port is installed at the same address, the test will give invalid results. Both serial tests will fail if R.A.C.E.R. II's special serial loop-back plug is not connected to the appropriate COM port.

### Test P (Hex: 10) — EGA Video Card Test

If R.A.C.E.R. II detects that an EGA video card is installed in the system, it will verify that the EGA's BIOS chip is functioning properly. This test will fail if an EGA video adapter is not installed in the system.

### Test Q (Hex: 11) — Monochrome Video RAM Test

If a monochrome video card is installed in the system, this test checks all of the video adapter's RAM. R.A.C.E.R. II graphically displays the test results. This test will fail if a monochrome video adapter is not installed in the system, or errors are detected in the video RAM.

## Test R (Hex: 12) — CGA Video RAM Test

If a CGA video card is installed in the system, this test checks all of the video adapter's RAM. R.A.C.E.R. II graphically displays the test results. This test will fail if a CGA video board is not installed in the system, or errors are detected in the video RAM.

## Test S (Hex: 13) — Video Character Set Test

This test displays the character set from the video display adapter(s) being used. **There is no pass/fail indication when running this test**, simply verify whether the character set is displayed or not.



# Chapter 5

## AT (80286/80386) Tests

---

---

This chapter describes the tests R.A.C.E.R. II executes when you run component-level diagnostics on an IBM AT or compatible computer equipped with an 80286 or 80386 microprocessor. Differences between the CPUs are indicated where applicable in the test descriptions.

The major differences between 80286 and 80386 machines are:

- ◆ The microprocessor (CPU)
- ◆ 16-bit vs. 32-bit data bus
- ◆ Math coprocessors 80287 (for 286s) vs. 80387 (for 386s)
- ◆ System clock speeds and timing differences
- ◆ Second 74LS612 DMA Page Register (80386 only)

---

### Test Descriptions

In the following descriptions, each test's title includes the letter used to identify the test on R.A.C.E.R. II's diagnostic displays, and the corresponding hexadecimal number used to identify the test on the numeric display.

#### Self Test

The first test R.A.C.E.R. II performs is a Self Test. This test insures that R.A.C.E.R. II's hardware and firmware is operating properly. If this test passes, you will hear an audible beep indicating that R.A.C.E.R. II has properly initialized.

## Test A (Hex: 01) — 8254 Timer Circuit

R.A.C.E.R. II loads a count into each of the three timer channels and then verifies that each channel counts down at the correct pace (not too fast or too slow).

In the AT's design, channel 0 of the 8254 is implemented as a general purpose timer providing a constant time base for the time-of-day clock. It is tied directly to the 8259 Interrupt Controller's channel 0 and cycled 18.2 times a second (54.936 millisecond resolution).

*Channel 1, which is the most important of the three,* is cycled every 15.12 microseconds. It is used in the dynamic memory refreshing routine to ensure that a full refresh cycle is initiated at least once every 2 milliseconds.

The last channel used in the AT design is channel 2. This channel is used to generate a sine wave which is routed to the speaker. Unlike channels 0 and 1, channel 2 is not as critical to the AT's operation. This channel is used to produce audio signals.

## Test B (Hex: 02) — 8237 DMA Controller 1, Channels 0 - 3

R.A.C.E.R. II tests all registers and status ports of the first of two 8237 DMA Controllers during this test.

The 8237 DMA controller chip is very critical to the AT's operation. It contains four separate channels that allow I/O devices to have direct access to the AT's system RAM for high speed data transfers without using the 80286 or 80386 microprocessor. Once programmed, the DMA controller can signal the processor to leave the bus temporarily so that it may complete the actual data transfer by itself at high speeds. The



8237 DMA controller can actually address and transfer only up to 64K bytes at a time, so additional circuitry is added in the AT's design to accommodate the extra address lines needed to access the entire 16 megabytes of memory.

The AT system is designed with two 8237 DMA controllers. DMA Controller 1 contains channels 0 - 3. Channel 0 is a spare, channel 1 is reserved for networks, channel 2 is used by the drive controller, and channel 3 is a spare.

Each DMA channel has a 6-bit mode word and four 16-bit registers. R.A.C.E.R. II fully tests all of these registers.

## Test C (Hex: 03) — 8237 DMA Controller 2, Channels 4 - 7

This test is identical to Test B, except it tests the second of the two 8237s. DMA Controller 2 contains channels 4 - 7. Channel 4 is used to cascade channels 0 - 3 of DMA Controller 1.

Each DMA channel has a 6-bit mode word and four 16-bit registers. R.A.C.E.R. II fully tests all of these registers.

## Test D (Hex: 04) — Memory Refresh Circuit

R.A.C.E.R. II verifies the RAM Refresh Circuit during this test. The AT uses channel 1 of the 8254 Timer chip and a dedicated counter for the refresh circuit.

Dynamic Memory Refresh (DMR) is an event that must be executed at least once every 2 milliseconds in order to retain valid data in the system RAM. For DMR to function properly, the following must work: 8254 timer channel 1, which issues a refresh request every 15.12 microseconds, and a TTL counter used to generate the memory's refresh address.

During this test the 8254 Timer/Counter is initialized to perform the refresh function. A pattern of data is then written to RAM, and after a delay of 3 seconds, the pattern is checked for data integrity.

#### Test E (Hex: 05) — 74LS612 DMA Page Register 1

The 74LS612 Page Register is used in the AT design to extend the addressing of the 8237 DMA Controllers. R.A.C.E.R. II reads and writes all of the control and address registers of the 74LS612 chip during this test. This test will verify the 74LS612 and its support circuitry.

#### Test F (Hex: 06) — 74LS612 DMA Page Register 2 (80386 Only)

This test is identical to test E, except it tests the second of the two 74LS612s. It tests all address registers and support circuitry of the DMA page register. *The second 74LS612 is on 80386 systems only.* Note that some 80386s fail this test because the chip is not in the circuitry, especially system boards which use Chips & Technologies chip sets.

#### Test F (Hex: 06) — 8259 Interrupt Controller 1, Channels 0 - 7 (80286 only)

#### Test G (Hex: 07) — 8259 Interrupt Controller 1, Channels 0 - 7 (80386 only)

R.A.C.E.R. II verifies the first of two Interrupt controllers during this test. All eight channels of the 8259 are checked for stuck, false, or missing interrupts.

Interrupt Controller 1 is used by the AT to prioritize up to seven system hardware interrupt requests and then send a master interrupt to the CPU.

The AT uses channel 0 for a real-time clock update. Channel 1 of the 8259 is used by the keyboard whenever a key is pressed. Channel 6 is used by the floppy disk drive. Channel 2 is used to cascade Interrupt Controller 2. The rest of Interrupt Controller 1's channels are used by serial and parallel ports.

#### Test G (Hex: 07) — 8259 Interrupt Controller 2, Channels 8 - 15 (80286 only)

#### Test H (Hex: 08) — 8259 Interrupt Controller 2, Channels 8 - 15 (80386 only)

R.A.C.E.R. II verifies the second of two Interrupt Controllers during this test. All eight channels of the 8259 are checked for stuck, false, or missing interrupts.

Interrupt Controller 2 is used by the AT to prioritize up to eight system hardware interrupt requests and then send a master interrupt to the CPU.

Channel 8 is used by the CMOS Clock/Calendar. Channel 13 is dedicated to the 80287/80387 math coprocessor. The AT's hard disk drive uses channel 14, and the rest of Interrupt Controller 2's channels are reserved for system expansion (i.e., Local Area Networks).

#### Test H (Hex: 08) — 8042 Processor (80286 only)

#### Test I (Hex: 09) — 8042 Processor (80386 only)

R.A.C.E.R. II verifies the correct operation of the AT's 8042 keyboard processor during this test. R.A.C.E.R. II first issues a software reset to the 8042 processor and checks the 8042's results. If the reset function passes, then R.A.C.E.R. II programs the 8042 processor to perform its Self Test stored in the 8042 ROM.

The 8042 keyboard processor is programmed to support the IBM AT serial keyboard interface.

### Test I (Hex: 09) — Keyboard (80286 only)

R.A.C.E.R. II performs a full test of the AT's keyboard circuit. First, the system's 8042 processor is verified, then R.A.C.E.R. II sends a software reset to the system's keyboard. If these tests pass, then R.A.C.E.R. II checks for any *hot* (stuck) keys.

- ◆ If this test fails and Test H (8042 Processor) passed, suspect the keyboard.

### Test J (Hex: 0A) — 80287/80387 Coprocessor

If detected, R.A.C.E.R. II tests the system's math coprocessor. R.A.C.E.R. II does not attempt to test 100% of the 80287/80387, but if this test passes, chances are high that the 80287/80387 is fully functional. R.A.C.E.R. II checks the operational interface between the microprocessor and the coprocessor.

### Test K (Hex: 0B) — Video Switch Setting

R.A.C.E.R. II reads the status of the Video Switch (sometimes a jumper instead of a slide switch) and displays the setting on the monitor.

### Test L (Hex: 0C) — 80286/80386 Microprocessor

R.A.C.E.R. II tests the control, address, data, and flag registers of the AT's CPU.

### Test M (Hex: 0D) — System Base RAM (0 - 640K)

R.A.C.E.R. II tests the validity of the system RAM. During this test, the base system memory map (0 - 640 K) is tested whether all memory is installed or not.

Pass/fail messages and a bit map are graphically displayed to facilitate the location of failure. All 16 data bits (32 bits in 80386 mode), and the 2 parity bits (4 bits in 80386 mode), are checked. Errors are displayed as a highlighted block on the memory map. The parity bit is generated with every memory write cycle and stored. When reading memory, this parity bit is checked and a *parity check* error is displayed if it is not the same as when written.

As mentioned above, 640K of RAM is tested whether that amount is installed or not. Therefore, failure of an entire bank can mean that it is not installed or that it is completely malfunctioning.

R.A.C.E.R. II does not attempt to check any memory above 1 megabyte due to the fact that *R.A.C.E.R. II has to assume the system is dead*. To check memory above 1 megabyte requires the AT to be almost 100% good. If R.A.C.E.R. II attempted to test the extended RAM and the system was not functional, R.A.C.E.R. II would *hang* (lock up).

### Test N (Hex: 0E) — 146818 CMOS Clock

The AT is designed with a Real-Time Clock Chip that is used by the system every time it is turned on. The 146818 Clock Chip contains the system's Real-Time Clock and 64 bytes of battery-backed CMOS RAM.

The first 14 bytes of RAM are used by the clock, and the rest is used by the system to store configuration information. The AT

stores the type and number of drives, the total amount of system RAM, and the type of video display in the 146818's RAM.

R.A.C.E.R. II tests the control and data registers in the 146818 CMOS Clock during this test. If this test passes, then R.A.C.E.R. II will load a count into the 146818 CMOS Clock and verify that the clock counts correctly.

#### Test O (Hex: 0F) — Serial Port 1

During this test, R.A.C.E.R. II looks for serial port 1 (COM1) at a base address of 3F8 H. If COM1 is detected, its operation is checked using two methods. First, R.A.C.E.R. II tests the UART chip on the serial card by performing an internal loop-back. If this test passes, then an external loop-back test is performed using R.A.C.E.R. II's special serial test plug. Note that you must connect the external loop-back connector supplied with R.A.C.E.R. II to COM1 in order for the second part of this test to be performed successfully.

#### Test P (Hex: 10) — Serial Port 2

During this test, R.A.C.E.R. II looks for serial port 2 (COM2) at a base address of 2F8 H. If COM2 is detected, its operation is checked using two methods. First, R.A.C.E.R. II tests the UART chip on the serial card by performing an internal loop-back. If this test passes, then an external loop-back test is performed using R.A.C.E.R. II's special serial test plug. Note that you must connect the external loop-back connector supplied with R.A.C.E.R. II to COM2 in order for the second part of this test to be performed successfully.

#### NOTE

If more than one serial port is installed at the same address, the test will give invalid results. Both serial tests will fail if R.A.C.E.R. II's special serial loop-back plug is not connected to the appropriate COM port.

#### Test Q (Hex: 11) — Printer Port 1

During this test, R.A.C.E.R. II looks for LPT1 at a base address of 3BC H. If LPT1 is detected, R.A.C.E.R. II reads and writes printer port 1's DATA and STATUS ports by performing an internal loop-back test.

#### Test R (Hex: 12) — Printer Port 2

During this test, R.A.C.E.R. II looks for LPT2 at a base address of 378 H. If LPT2 is detected, R.A.C.E.R. II reads and writes printer port 2's DATA and STATUS ports by performing an internal loop-back test.

#### NOTE

If more than one printer port is installed at the same address, the test will give invalid results.

#### Test S (Hex: 13) — EGA Video Card Test

If R.A.C.E.R. II detects that an EGA video card is installed in the system, it will verify that the EGA's BIOS chip is functioning properly. This test will fail if an EGA video board is not installed in the system.

## Test T (Hex: 14) — Monochrome Video RAM Test

If a monochrome video card is installed in the system, this test checks all of the video adapter's RAM. R.A.C.E.R. II graphically displays the test results. This test will fail if a monochrome video board is not installed in the system, or there are video RAM errors.

## Test U (Hex: 15) — CGA Video RAM Test

If a CGA video card is installed in the system, this test checks all of the video adapter's RAM. R.A.C.E.R. II graphically displays the test results. This test will fail if a CGA video board is not installed in the system, or there are video RAM errors.

## Test V (Hex: 16) — Keyboard Lock

This test is an aid to see if the AT's keyboard lock circuit is functional. R.A.C.E.R. II displays the status of the keyboard lock circuit (locked/unlocked).

## Test W (Hex: 17) — Video Character Set Test

This test displays the character set from the video display adapter(s) being used. **There is no pass/fail indication when running this test**, simply verify whether the character set is displayed or not.

# Chapter 6 Reference

---

---

## Troubleshooting a Dead System

This section provides guidelines on troubleshooting a *dead* PC. A *dead* system (PC, XT, or AT) is a computer that has such severe problems that even R.A.C.E.R. II cannot initialize the computer.

**Power Supply** — The system's power supply *must* be good to allow the system and R.A.C.E.R. II to run. Usually a bad power supply is not the problem; however, to assist you in verifying that the power supply is OK, R.A.C.E.R. II has four power supply indicators that indicate whether or not the power supply is functioning properly. R.A.C.E.R. II also beeps right after the system is powered up indicating that it initialized OK. If all four power supply indicators are steadily illuminated (not flickering), and you hear R.A.C.E.R. II beep after power-up, you can assume that the power supply is OK.

If you suspect that the power supply is the problem, first check the connection between the system board and the power supply. The illustration on the next page shows the correct connection between the power connector on the motherboard and the power supply. **If the power supply is improperly wired to the motherboard, permanent damage can occur to R.A.C.E.R. II.**

If system board/power supply connection is OK, then try swapping power supplies to see if that corrects the problem.

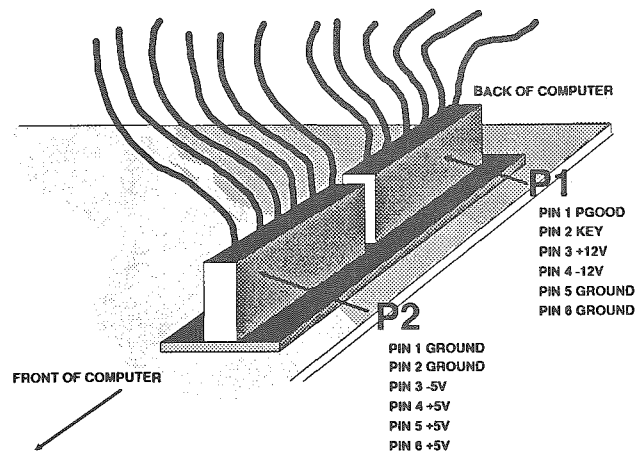

*Motherboard Power Connector*

**CAUTION!**

Permanent damage will occur to R.A.C.E.R. II if the power supply is plugged into the system board backwards!

**No Video** — If the power supply is not the problem, but there is no video, check the following:

- ◆ Make sure the monitor is turned ON.
- ◆ Make sure the monitor is connected to the correct video card.
- ◆ Make sure the monitor's contrast and brightness controls are set at mid-range.
- ◆ Make sure the video card is operational and fully *seated* in its expansion slot.
- ◆ Make sure you're using a monochrome or CGA video card which is compatible with R.A.C.E.R. II (see *Video Display Compatibility* in Chapter 3 for details).

**R.A.C.E.R. II BIOS ROMs (Special XT or 80286/80386)** — If the system being tested is an 80286 or 80386 based machine or

special XT that R.A.C.E.R. II fails to initialize, make sure that R.A.C.E.R. II's BIOS chips (which replace the system BIOS chips) are installed correctly (i.e., that they are properly oriented and are fully seated in their sockets - see *Installing the R.A.C.E.R. II Board* in Chapter 3 for instructions). If you are unsure which socket is **HIGH** and which is **LOW**, try both ways; you can also refer to the *High and Low BIOS Placement Reference* listing later in this chapter under *Troubleshooting AT Computers*.

**Microprocessor (8088, 80286, and 80386)** — The failure rate of these chips is very low, but since the microprocessor is socketed it can easily be replaced. If you suspect the CPU, replace it *before* unsoldering other chips on the system board.

**8237 DMA Controller** — The 8237 DMA Controller has a high failure rate and should be suspected. The 8237 can be disabled by placing a jumper from pin 10 (HOLD REQUEST) and pin 20 (GROUND). If R.A.C.E.R. II runs after this, replace the 8237 chip.

**CAUTION!**

Never install or remove jumpers with system power ON!

**System Clock Generators [8284 (PC/XT), 82284 (80286), 83384 (80386)]** — This circuit must be working, since it supplies the master system timing and reset. This chip's failure rate is low.

**System Bus Controller [8288 (PC/XT), 82288 (80286), 83388 (80386)]** — This chip generates all system bus controls and read/write signals. Failure rate is low.

**Main ADDRESS and DATA Buffers and Latches** — These chips must be operational and the failure rate is low. Usually 74LS373 and 74LS245 chips are used.



## Troubleshooting PC and XT Computers

This section provides the following reference information for troubleshooting PC and XT computers:

- ◆ Troubleshooting Cross-Reference Table for DTK PIM XT Motherboard
- ◆ ACER 710 Computer Troubleshooting Reference
- ◆ PC/XT Advanced Troubleshooting Reference

### Troubleshooting Cross-Reference Table for DTK PIM XT Motherboard

The following table provides problem/solution identification and chip cross-reference information for the DTK PIM system board used in many PC and XT computers.

IBM XT U#	PIM XT U#	IBM PC U#	CHIP & SIGNAL	SYSTEM PROBLEM	SOLUTION For PIM XT
U70	U82	U82	74LS74 HLDA, NMI	DEAD	GROUND U83-4 74LS175 DMA AEN  REPLACE U82 IF R.A.C.E.R. RUNS
U88	U83	U98	74LS175 DMAWAIT, AEN	DEAD	REPLACE CHIP
U87	U98	U97	74LS08 RDYDMA, NMI	DEAD	GROUND 8088-17  REPLACE U98 IF R.A.C.E.R. RUNS
	U12		74LS20 DT/R TO XD0-XD7	DEAD	GROUND U17-11  REPLACE U12 IF R.A.C.E.R. RUNS

IBM XT U#	PIM XT U#	IBM PC U#	CHIP & SIGNAL	SYSTEM PROBLEM	SOLUTION For PIM XT
U70	U65	U82	74LS74 I/O CHRDY, RDY/WAIT, DRQ0	DEAD	GROUND U83-12  NOTE: THE SCREEN MAY HAVE "SNOW" REPLACE U65 IF R.A.C.E.R. RUNS
U23	U24	U27	74LS02 ROM ADDSEL, DT/R XD0-7	DEAD	GROUND U17-10  REPLACE U24 IF R.A.C.E.R. RUNS
U28	U36	U35	8237 DMA HLD	DEAD	GROUND U37-10  REPLACE U36 IF R.A.C.E.R. RUNS
	U99	U81	74S00 DMA AEN, RAMSEL	DIES IN RAM TEST	REPLACE U99
	U50		74LS32 MWE	RANDOM RAM FAILURES NOT DUE TO RAM CHIPS	REPLACE U50
	U67	U99	74LS04 RESET PARITY F/FLOW	RAM PARITY ERRORS NOT DUE TO RAM	GROUND U52-13  REPLACE U67 IF PARITY ERROR IS FIXED.
	U13	U12	74LS245 MD0-MD7 BUFFER	RANDOM RAM FAILURES NOT DUE TO RAM CHIPS	REPLACE U13
U10	U26	U19	74LS670 DMA PAGE REGISTER	RUNS ALL TESTS ON R.A.C.E.R. BUT WILL NOT RUN DISK DRIVES	REPLACE U26
	U9	U17	74LS244 DMA A0-7 BUFFER	RUNS ALL TESTS ON R.A.C.E.R. BUT WILL NOT RUN DISK DRIVES	REPLACE U9
	U15	U18	74LS373 DMA A8-A15 LATCH	RUNS ALL TESTS ON R.A.C.E.R. BUT WILL NOT RUN DISK DRIVES	REPLACE U15

IBM XT U#	PIM XT U#	IBM PC U#	CHIP & SIGNAL	SYSTEM PROBLEM	SOLUTION For PIM XT
	U66		74LS20 HLDRQT DMA	RUNS ALL TESTS ON R.A.C.E.R. BUT WILL NOT RUN DISK DRIVES	REPLACE U66
U45	U51	U66	74LS138 CHIPSELECT	FAILS ON 8237, 8253 8259 AND PARITY	REPLACE U51
U21	U27	U26	74LS175 8253 CLOCK	FAILS ON 8253 AND SPEAKER	REPLACE U27  NOTE: IF 8253 IS SOCKETED TRY IT FIRST
U17	U10	U16	74LS244 XA0-XA7 BUFFER	FAILS ON BIOS, 8253, 8237, 8255, DIP SWITCH, AND RAM	REPLACE U10
U15	U14	U13	74LS245 XD0-XD7 BUFFER	FAILS ON BIOS, 8253, 8259, 8255, DIP SWITCH AND PARITY	REPLACE U14
	U16		74LS244 XA8-XA15 BUFFER	FAILS ON BIOA, 8253, 8259, 8255, 8237, PARITY AND DIP SWITCH	REPLACE U16
U13 (LS243)	U22	U14	74LS245 XMWE/RD, XIORD, XIOWE	FAILS ON BIOS, 8253, 8237, 8259, 8255, RAM, SPEAKER & DIP SWITCH	REPLACE U22
	U19		7407 MUX	FAILS ON DIP SWITCH	REPLACE U19
	U17		74LS27 DT/R TO XD0-XD7	FAILS ON BIOS, 8253, 8259, 8237, 8255, RAM & DIP SWITCH	REPLACE U17

## ACER 710 Computer Troubleshooting Reference

**ACER 710 MT86G011 Chip** — Cross reference using a MT86G011 chip. The following functions are incorporated within the chip:

- ◆ 82C88 Clock Generator
- ◆ 82C37 DMA Controller - channel 0 is used for refresh.
- ◆ 82C59 Interrupt Controller - 8 channels
- ◆ 82C53 Timer
- ◆ 82C55 Peripheral I/O
- ◆ Parity Check Circuit
- ◆ Wait-state Logic
- ◆ ROM Decoder - 2764/27256 or 27256/27256
- ◆ RAM Decoder - 256K or 1 Mb DRAMs
- ◆ EMS Extension Memory Bank function
- ◆ H/W and S/W CPU Speed Change function
- ◆ 4.77 MHz DMA Clock

If any of the above circuits are the cause of R.A.C.E.R. II's failure and are not associated with support chips, then replace the chip and test again.

## PC/XT Advanced Troubleshooting Reference

The following provides more in-depth troubleshooting guidelines and techniques to isolate failures in PC and XT computers which R.A.C.E.R. II fails to initialize.

1. Check for clock on pin eight of the clock chip (8284 - U11 on PCs and U1 on XTs). If no clock is detected, the possible cause is a bad 8284 crystal.
2. Check for clock at pin 8 of the 74LS04 (U51 on PCs, U89 on XTs). Replace the chip if there is no clock.
3. Check for clock on pin 4 of the time delay (TD2 on PCs and XTs) If no clock is found, remove the time delay and replace with a 470 Ohm resistor across pins 1 and 4 on the system board.
4. Check the signal at pin 9 of the 74LS74 (U96 on PCs, U86 on XTs) for a high or floating signal. If a high or floating signal is found on this pin, replace the chip. This signal is the Allow Non-Maskable Interrupt.
5. If none of the above checks correct the problem, try replacing the 8088 processor, which is socketed.

## Troubleshooting AT Computers

This section provides the following reference information to aid in troubleshooting 80286 and 80386 based systems:

- ◆ High and Low BIOS Placement Reference
- ◆ Advanced Troubleshooting - IBM AT Model 5170-239 Motherboard
- ◆ Chip Set Cross Reference

### High and Low BIOS Placement Reference

The following provides chip identification references for HIGH and LOW system BIOS ROMs for a variety of computers.

When replacing system BIOS chips with R.A.C.E.R. II's AT or special XT BIOS chips, check the labeling (if any) on the system BIOS chips against the following list to see if you can accurately identify which chip is HIGH and which is LOW (R.A.C.E.R. II's BIOS chips are marked for easy identification).

If you cannot determine which system BIOS chip is HIGH and which is LOW, you can try each of R.A.C.E.R. II's BIOS chips in each IC socket (having the HIGH and LOW chips reversed won't damage the chips); BUT, make sure the *orientation* of the R.A.C.E.R. II BIOS chips is correct (if the chips are installed backwards, they can be damaged - see step 5 under *Installing the R.A.C.E.R. II Board* in Chapter 3 for details).

HIGH = 1 = ODD  
LOW = 0 = EVEN

#### 512K XT-286 IBM Original

U27 = LOW  
U47 = HIGH

### 640K XT-286 IBM Original

U34 = LOW  
U35 = HIGH

### 512K 286 AT - 5170-239

U27 = LOW  
U47 = HIGH

### MULTITECH 512K AT

U53 = LOW  
U51 = HIGH

### DTK Ver 2 10 MHz Motherboard - PTM-1000 286 V.2

U46 = LOW  
U51 = HIGH

### DTK PTM-1030 - Mini AT Motherboard

U43 = LOW  
U42 = HIGH

### DTK 386-16 Motherboard - FAST ET 16v2

U23 = LOW  
U21 = HIGH

### PC CALC AT TURBO 286

U44 = LOW  
U46 = HIGH

### ATI 1000 - 10 MHz Motherboard

U84 = LOW  
U82 = HIGH

### ACER 1100 386 System

U41 = LOW  
U43 = HIGH

### ACER 910 286 System

U43 = LOW  
U44 = HIGH

## Advanced Troubleshooting IBM AT Model 5170-239 Motherboard

The following provides advanced troubleshooting techniques for using an oscilloscope to further isolate failures which R.A.C.E.R. II's diagnostics identifies on IBM AT or compatible systems (80286 CPU *only*) which utilize the 5170-239 (or compatible) motherboard:

### 12 MHz Oscillator – Check the following:

Check for logic High Power Good Signal at pin 11 of Clock Generator IC 82284 (U82). If the reading is not correct, check the power supply for proper operation.

If the reading is correct, check for a 12 MHz waveform at pin 10 of IC 82284 (U82). If the waveform is missing, check Crystal Y2, Capacitor C71 and C72, and IC 82284 (U82).

If the waveform is good, check for 12 MHz pulses at pin 11 of IC 74F00PC (U96). If pulses are missing, check 74F00PC (U96).

If pulses are present, check for 6 MHz waveform at pin 9 of IC SN74LS112AN (U88) and pin 5 of IC 74F74PC (U51). If waveforms are missing, check each IC.

### 14.318 MHz Oscillator – Check the following:

Check for a 14.318 MHz waveform at pin 12 of IC 8284A (U18). If the wave form is missing, check crystal Y1, Trimmer capacitor C26, IC 8284A (U18) and resistors R1 and R2.

If the waveform is good, check for 2.38 MHz pulses at pin 1 of IC SN74LS112AN (U88). If pulses are missing, check IC 8284A (U18).

If the pulses are present, check for 1.19 MHz waveform at pin 5 of IC SN74LS112AN (U88). If the waveform is missing, check IC (U88).

### 32.768 KHz Oscillator – Check the following:

Check for 32.768 KHz waveform at pin 10 of IC MC14069U (U108). If the waveform is missing, check Crystal Y3, Capacitor C83, IC 108, and resistor R27.

### Microprocessor IC (U74) – If the 80286 CPU does not appear to be functioning:

Check for 12 MHz waveform at Pin 10 of the Clock Generator IC 82284 (U82). If the waveform is not present, repeat the tests in Oscillator section.

If the waveform is good, check the operation of the Reset circuit. Check the logic reading at pin 12 of IC 82284 (U82) while turning the computer on. The reading should be logic High immediately after powering up the computer, then go logic Low after about 0.2 seconds. If the reading is not correct, check IC 82284 (U82).

If the reading is correct, check for a logic Low, that goes High 0.2 seconds after turning the computer on, at pin 4 of IC SN74ALS02N (U99) and pin 4 of IC SN7407N (U116). If the reading is not correct, check both chips.

If the reading is correct, check for logic High at pin 9 of IC SN74ALS00AN (U94). If the reading is not correct, check ICs U105 and U106 (SN74ALS74AN).

If the reading is correct, check for a logic High that goes Low 0.2 seconds after turning the computer on, at pin 8 of IC SN74ALS00AN (U94). If the reading is not correct, check IC U94.

## Chip Set Cross Reference

The following identifies the functions controlled by various chip sets from different manufacturers which are used in 80286 and 80386 based systems. You can use this listing to help you determine which chip or chips to replace depending on the problems reported by R.A.C.E.R. II diagnostics. For example, if the computer you're testing uses a Chips & Technologies CS8230 chip set and R.A.C.E.R. II identifies a DMA problem, then you would know to replace the 82C201 chip by referring to the CS8230 chip set section under *Chips & Technologies*.

### ACC Chip Sets

#### ACC 82010 PC/AT 286/386

<u>Chip</u>	<u>Function</u>
ACC 2000	Integrated Peripheral Controller
ACC 2100	System Controller
ACC 2210	Data Bus Buffer
ACC 2220	Address Bus Buffer

#### ACC 82020 Hi-Speed 286/386 Chip Set

<u>Chip</u>	<u>Function</u>
ACC 2000	Integrated Peripheral Controller
ACC 2120	Enhanced System Controller
ACC 2210	Data Bus Buffer
ACC 2220	Address Bus Buffer
ACC 2300	Page Interleaved Memory Controller
ACC 2500	System Controller

#### ACC 2030 Single Chip 286 System Controller

#### ACC 2035 Single Chip 386SX System Controller

## Chips & Technologies Chip Sets

### CS8230 Chip Set

<u>Chip</u>	<u>Function</u>
82C201	System Controller Clock Generation Reset/Ready Synchronization Command and Control Signal Generation Conversion Logic Wait-State Control DMA and Refresh Logic Co-processor Control NMI and Error Logic
82C202	RAM/ROM Decoder and I/O Controller RAM/ROM Decoder Parity Error Detection Logic I/O Decode Logic
82C303	High Address BUS Buffer and Port B Chip High Address Bus Buffer for A17-A23 Memory and I/O Read/Write Signal Buffer Port B Status (61H)
82C204	Low Address BUS Buffer and Refresh Counter Provides Drive and Buffering for A1-A16 Provides Drive for MA0-MA7 Provides Refresh Counter SA0-SA7
82A205	Data Bus Buffer and Parity Generator Chip Provides Data Bus Buffer and Driver for D0-D15 >SD0-SD15 >MD0-MD15 ENHLB DIRHLB - Byte Conversion Logic Parity Generation and Check Logic

## Chips & Technologies Chip Sets (cont'd)

### CS8221

### NEAT Chip Set

<u>Chip</u>	<u>Function</u>
82C211	System Controller & Extended CMOS RAM Control Logic
82C212	I/O and Memory Decode
82C215	Parity Logic and Address & Data Bus Buffer
82C206	Integrated Peripheral Controller

### CS82235

### NEAT Chip Set Single Chip 286 System Controller

### CS8233

### PEAK 386/AT Chip Set

<u>Chip</u>	<u>Function</u>
82C311	CPU, Cache, DRAM Controller
82C316	Peripheral Controller
82C315	Bus Controller
82C452	Super VGA Controller
82C601	Single Chip Peripheral Controller
82C765	Single Chip Floppy Disk Controller

### Faraday FE3600B Chip Set

<u>Chip</u>	<u>Function</u>
FE3001	System Controller
FE3010	Peripheral Controller
FE3021	Address Bus and Memory Control Logic
FE3031	Parity and Data Bus Controller

## OPTI 286/386 Chip Sets

<u>Chip</u>	<u>Function</u>
82C381	System and Cache Memory Controller
82C382	Direct Mapped Page Interleaved Memory Controller

## Suntec Chip Sets

### **286 Chip Sets**

<u>Chip</u>	<u>Function</u>
ST62C201	System Bus Controller
ST62C202	Memory Controller
ST62C008	Integrated Peripheral Controller
ST62C010	Address Bus Controller
ST62BC001	System Controller
ST62BC002	High Address Buffer
ST62BC003	Low Address Buffer
ST62BC004	Data Buffer
ST62C005	I/O Control, DMA Page Register
ST62C006	Integrated Peripheral Controller

### **286/386SX Chip Set**

<u>Chip</u>	<u>Function</u>
GS62C101	System, Data Bus, Timer and Interrupt Controller
GS62C102	Memory, DMA, and I/O Controller

## Western Digital Chip Sets

<u>Chip</u>	<u>Function</u>
75C10	Single Chip 286 AT Controller
75C20	Floppy/Hard Drive and Real Time Clock Controller
75C30	Serial and Parallel Port Controller
76C10	Hi-Speed Single 286 AT Controller
WD6000	System, Interrupt and Timer Controller
WD6010	DMA, Reset, and Parity Controller
WD6020	Address and/or Data Bus Controller
WD6036	DRAM/Cache Memory Controller

## VIA FLEXSET Chip Sets

<u>Chip</u>	<u>Function</u>
SL9011	System Controller
SL9020	Data Bus Controller
SL9023	Address Controller
SL9151	286 Page Interleave Memory Controller
SL9152	286 System and Memory Controller
SL9250	386SX Page Mode Memory Controller
SL9251	386SX Page Interleave Memory Controller
SL9252	386SX System and Memory Controller
SL9350	386DX Page Mode Memory Controller
SL9351	386DX Page Interleave Memory Controller
SL9352	386DX System and Memory Controller
SL9030	Integrated Peripheral Controller
SL9090	Universal Clock Chip
SL9095	Power Management Chip

## VLSI Technology Chip Sets

### **TOPCAT 286/386SX Chip Set**

<u>Chip</u>	<u>Function</u>
VL82C331	ISA Bus Controller
VL82C320	System Controller
VL82C106	Combo I/O

### **TOPCAT 386DX Chip Set**

<u>Chip</u>	<u>Function</u>
VL82C330	System Controller
VL82C311	ISA Bus Controller
VL82C322	Data Buffer
VL82C106	Combo I/O

### **VL82CPCAT-16/20 Chip Set**

<u>Chip</u>	<u>Function</u>
VL82C203	Address Buffer
VL82C204	Data Buffer
VL82C100	Peripheral Controller
VL82C201	System Controller
VL82C202	Memory Controller

## Zilog Chip Sets

<u>Chip</u>	<u>Function</u>
P90	System, Interrupt, DMA, Clock and refresh controller
P91	Memory Controller
P92	Address and Data Bus Controller

## Zymos Chip Sets

<u>Chip</u>	<u>Function</u>
POACH/XTB	Single Chip XT Controller
POACH1	System Clock, Bus Controller, Interrupt and Real Time Clock
POACH2	DMA, Timer, Refresh and I/O Control Functions
POACH4	Single Chip XT Controller (8259, 8254, 8288, 8284, 8237, and 8255)
POACH6	Hi-Speed System Controller, 386DX and 486 systems
POACH7	System Clock, Bus Controller, Interrupt and Real Time Clock
POACH8	DMA, Timer, Refresh and I/O Controller



## Chapter 7

# System Block Diagrams

---

This chapter contains the following system block diagrams:

- ◆ IBM PC Clock Circuitry Block Diagram
- ◆ IBM XT Block Diagram
- ◆ IBM AT Compatible Block Diagram
- ◆ IBM AT Compatible Sub-Section Block Diagram
- ◆ IBM AT Compatible Local and System Bus
- ◆ IBM AT System Block Diagram
- ◆ 80386 System Block Diagram
- ◆ Chips & Technologies AT System Block Diagram
- ◆ VLSI AT System Block Diagram

You may wish to refer to these diagrams when troubleshooting a system with R.A.C.E.R. II to help you identify and locate malfunctioning components/circuits which the diagnostics have isolated for you.



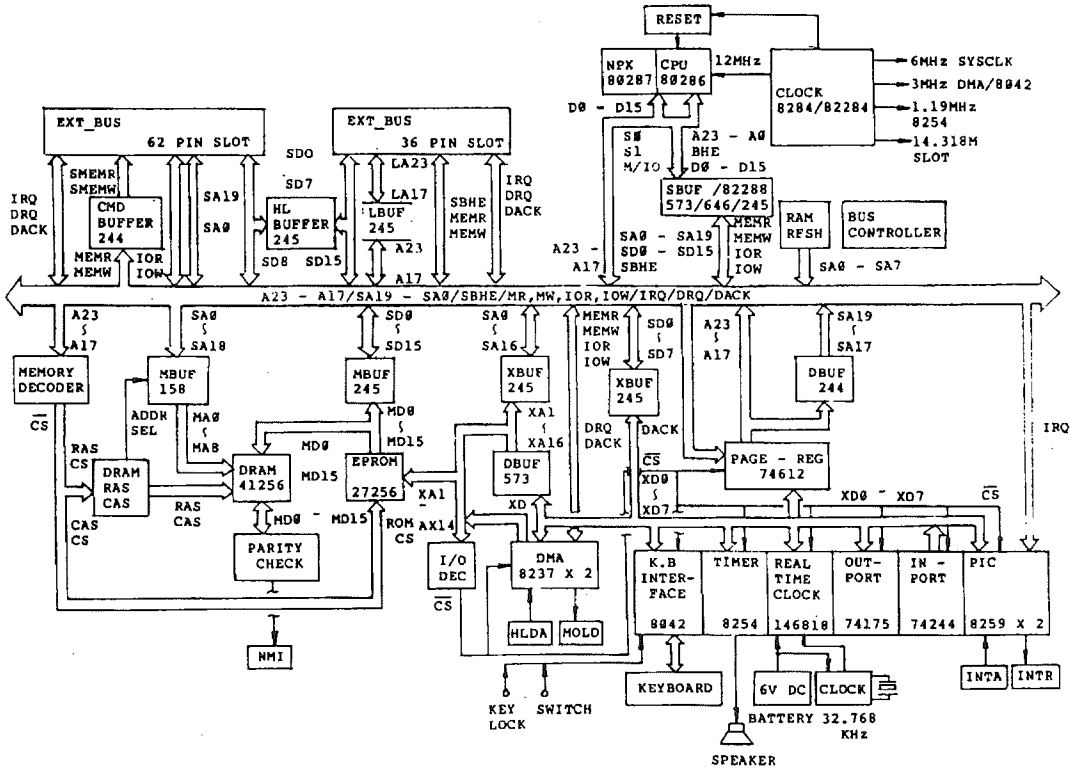

IBM AT Compatible Block Diagram

IBM AT Compatible Sub-Section Block Diagram

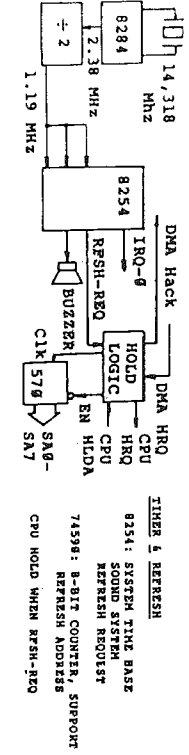
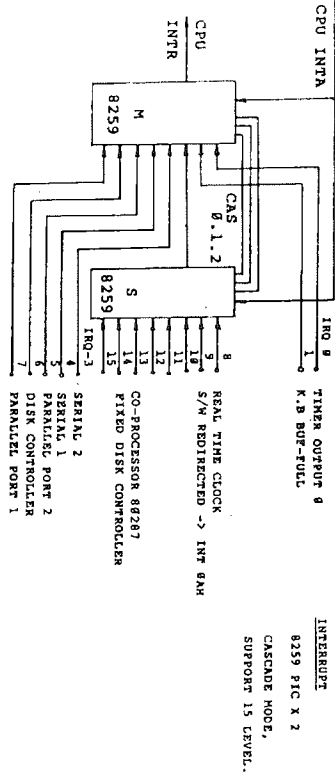
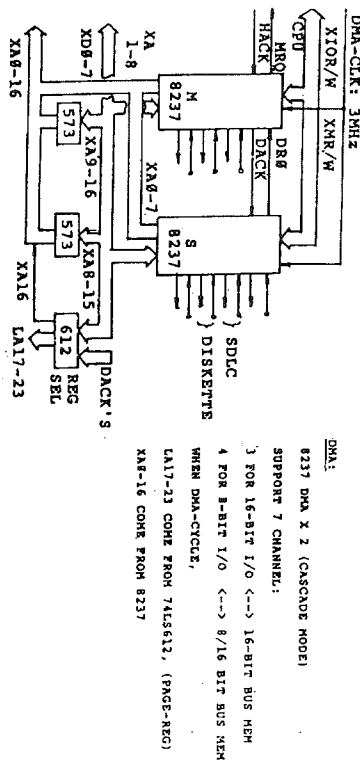

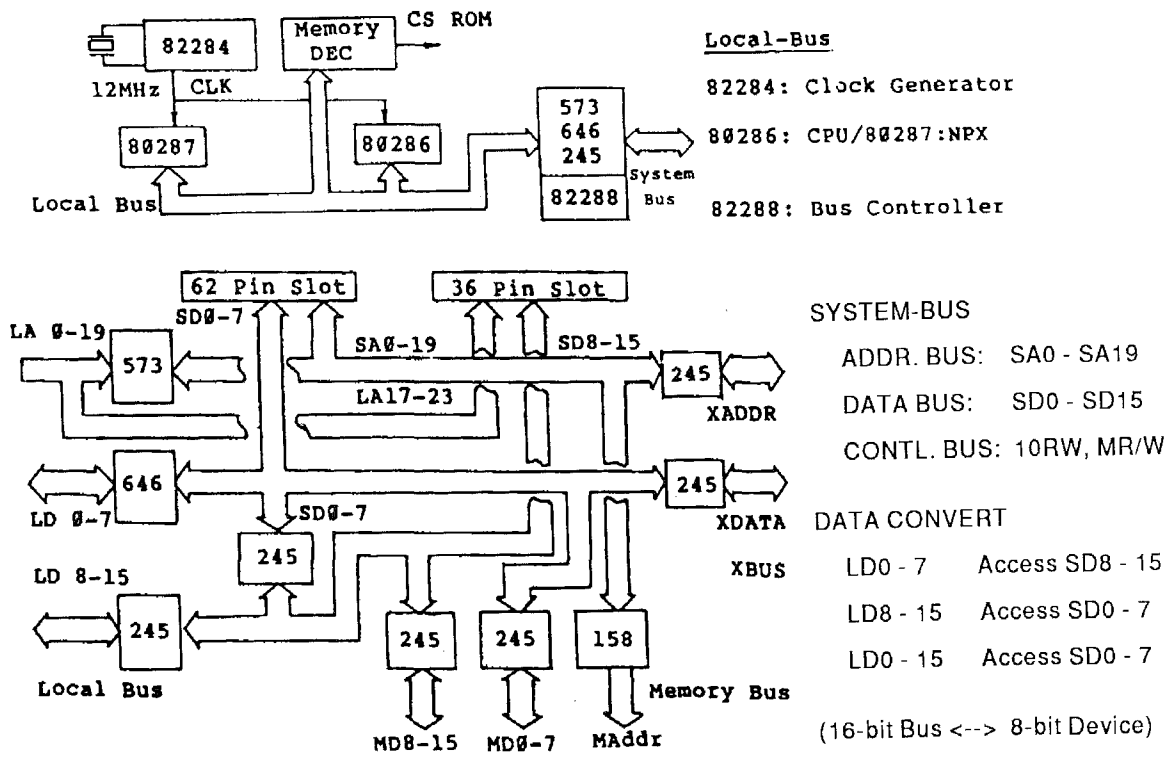

IBM AT Compatible Local and System Bus

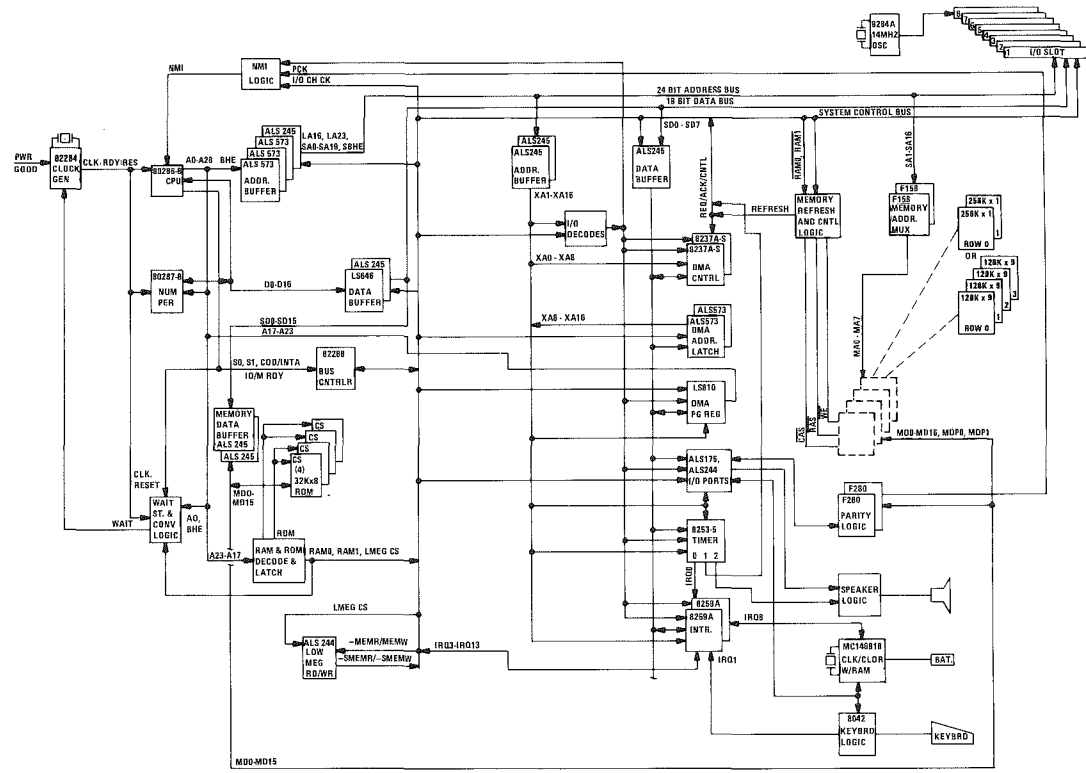
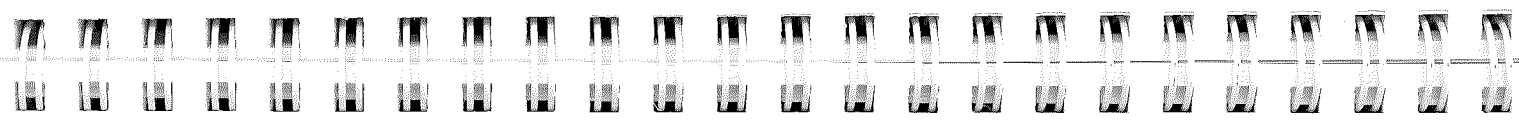

IBM AT System Block Diagram

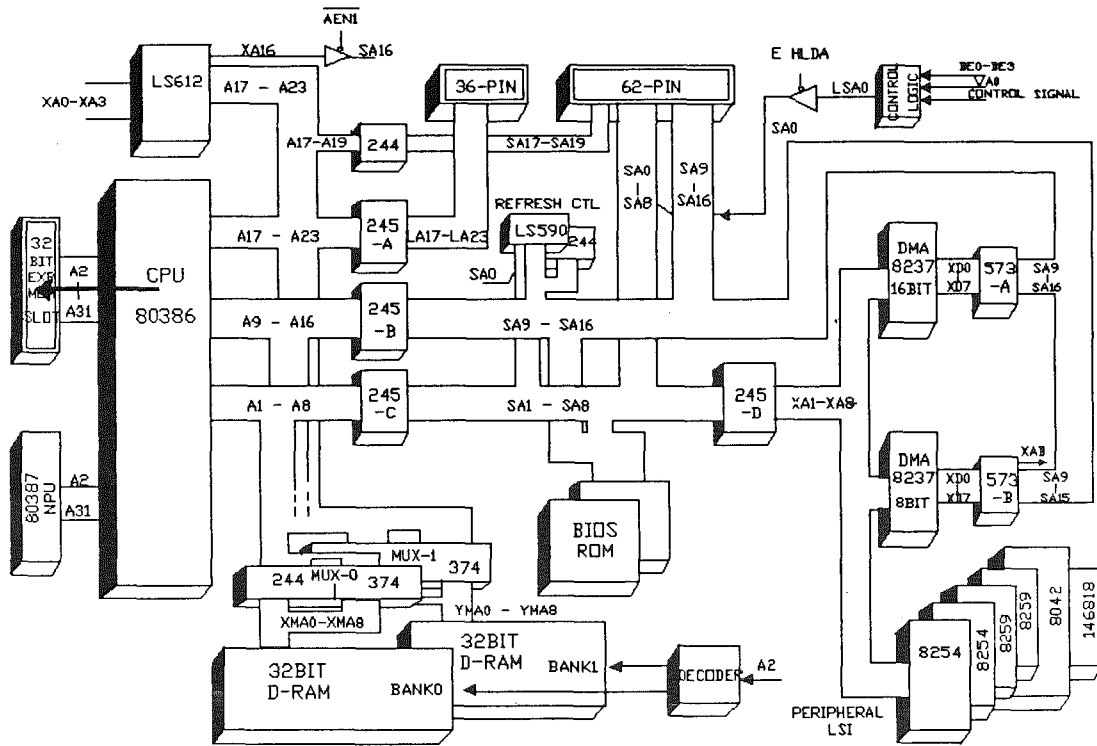

80386 System Block Diagram

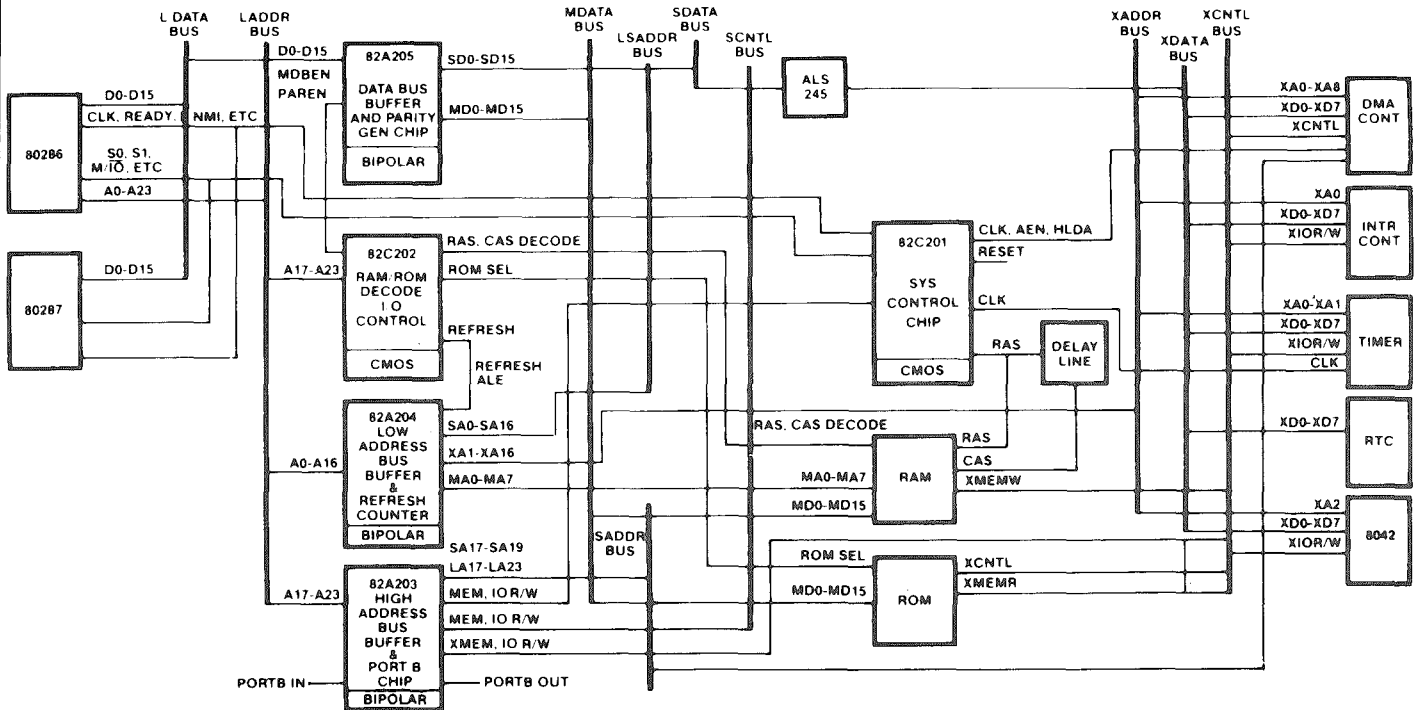
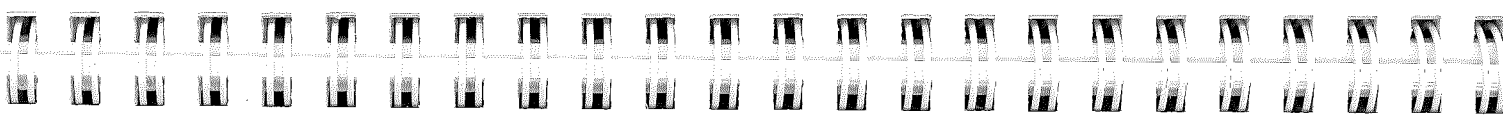

Chips & Technologies AT System Block Diagram

# Chapter 8

## POST Mode

### Overview

R.A.C.E.R. II's POST mode allows you to quickly and easily monitor Power On Self Test codes output by the system BIOS in IBM or compatible 80286, 80386, and 80486 based systems.

The POST mode compliments R.A.C.E.R. II's powerful component-level diagnostics by allowing you to utilize an AT system's own internal Power On Self Test routine to quickly identify potential problem areas. This can sometimes make it *easier* to troubleshoot and isolate component failures when subsequently using R.A.C.E.R. II's diagnostics mode, or, if the failure POST identifies is readily obvious, it can even eliminate the need to use R.A.C.E.R. II's diagnostics mode at all.

What is POST – Power On Self Test is a test sequence initiated and controlled by the system BIOS each time power is applied to the computer. The POST sequence starts when the computer is turned on and continues to the point when the system is *booted* (i.e., when the operating system is loaded). The purpose of the POST routine is to check all of the major functions and subsystems of the computer (such as the memory, keyboard, video, hard and floppy drives, etc.) to make sure everything is functioning properly before an attempt is made to load the operating system (e.g., DOS) and other programs which the computer may need to run.

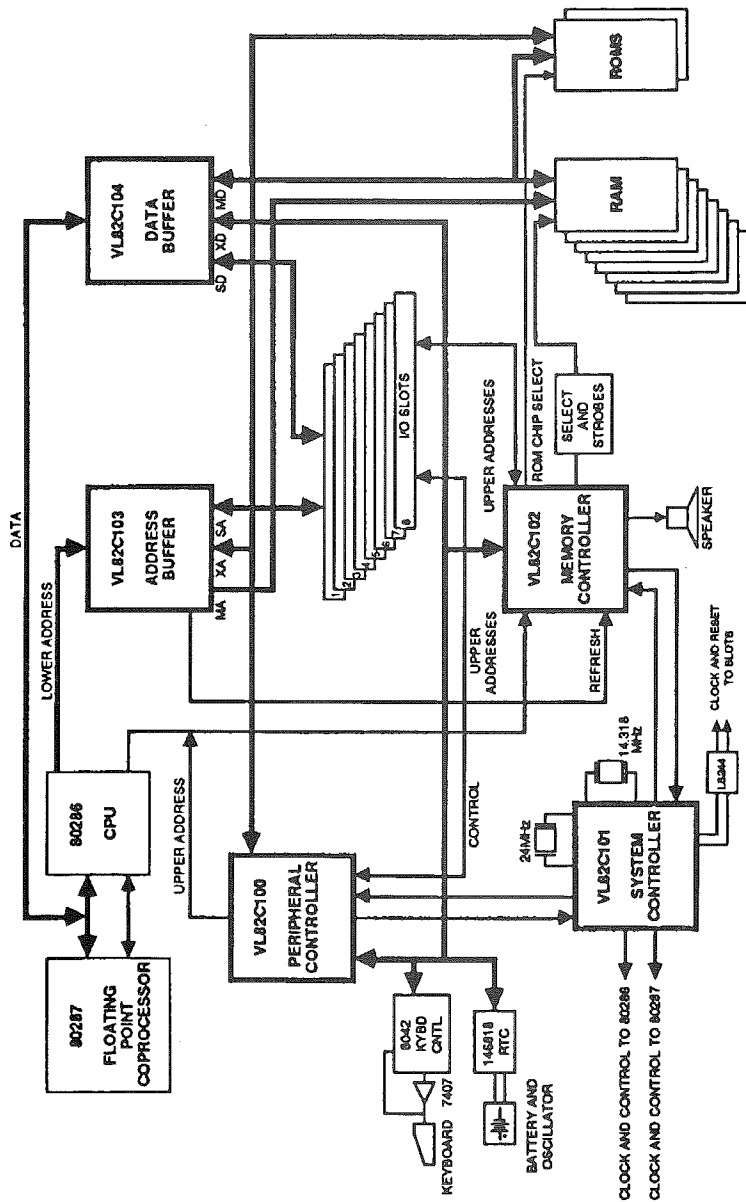

VLSI AT System Block Diagram

**What are POST Codes** — POST codes are transmitted by the system BIOS during the Power On Self Test sequence. POST codes are typically output as hexadecimal numbers. These numbers (or codes) identify each of the various components and functions (a circuit or group of circuits) that are tested after the system is powered up.

**Using the POST Mode** — To use R.A.C.E.R. II's POST mode, you simply install R.A.C.E.R. II in the computer you wish to test, set switch 9 on the 1-10 switch block to the ↓OFF (POST) position, apply power to the computer, and view the POST codes as they are displayed on R.A.C.E.R. II's easy to read numeric display.

If the POST sequence stops, the code displayed on the numeric display indicates the failure. By referring to the *POST Code Reference* section at the end of this chapter, you can quickly identify the problem.

For example, if you were testing an 80286, 80386, or 80486 based system equipped with a Phoenix BIOS, and the POST sequence stopped with code 27 displayed on R.A.C.E.R. II's numeric display, you would know by referring to the *Phoenix BIOS* section of the *POST Code Reference* that there was a problem with the keyboard controller. You could then perform more rigorous testing on the keyboard controller circuitry to further isolate the failure using R.A.C.E.R. II's component-level diagnostic mode.

**POST Mode Benefits** — Although R.A.C.E.R. II's diagnostic mode offers significantly more powerful testing and failure isolation capabilities than the POST routines supplied with 80286, 80386, and 80486 systems, there may be times when using the POST mode before running R.A.C.E.R. II diagnostics can prove valuable.

For example, if a system is not completely dead (is partially initializing), you can use the POST mode to make an initial

pass or two to see if the POST routine identifies any problems. By using the POST mode first, you may identify the problem without having to remove the system BIOS chips on the motherboard and replace them with R.A.C.E.R. II's AT BIOS ROMs, which is necessary when you use R.A.C.E.R. II's diagnostics mode to troubleshoot 80286 and 80386 based systems.

If the POST routine hangs, you then have an early indication of what the problem might be. If the problem is obvious and requires no further troubleshooting, then you simply replace the component(s) which POST identified as bad. If the problem appears to require further investigation, then you can use R.A.C.E.R. II's component-level diagnostics to exactly pinpoint the failure since the POST test has given you a good idea of what circuit or group of circuits are suspect.

The POST mode can also be used by programmers to debug software or firmware code. Since R.A.C.E.R. II's POST mode monitors port 80h, the most common port to which POST codes are output, programmers can simply embed sequential checkpoints in their code which are directed to address 80h. By running R.A.C.E.R. II in the POST mode when the program is executed, checkpoint numbers will then appear on the numeric display just like POST codes. If the program hangs during execution, it indicates that a bug exists in the code somewhere between the current number displayed and the previous checkpoint number.

---

## System Requirements

The following are the only requirements for using R.A.C.E.R. II's POST mode:

- ◆ The system must be an IBM AT or compatible computer equipped with an 80286, 80386, or 80486 microprocessor.

### NOTE

IBM or compatible XT, 8088, or 8086-based systems can be tested **providing the system's BIOS outputs POST codes**. Although most 8086, 8088, and XT computers do not generate POST codes, running R.A.C.E.R. II in POST mode on such systems will not do any harm to the computer. If the system's BIOS does not output POST codes, R.A.C.E.R. II's numeric display simply will not show anything after power-up. If you're unsure whether a system you wish to test outputs POST codes, refer to the BIOS or system board manufacturer's specifications.

---

## Running R.A.C.E.R. II in POST Mode

If you've never used a POST diagnostic board before, you may wish to initially use R.A.C.E.R. II's POST mode to test a system you know is functioning properly. By monitoring the POST codes and referring to the appropriate POST code reference table at the end of this chapter, you should be able to quickly get a feel for what the POST mode does and how it can help you isolate failures.

To use R.A.C.E.R. II's POST mode, we recommend you proceed as follows:

1. Install R.A.C.E.R. II in a computer you wish to test by following the installation instructions in Chapter 3.
2. To set R.A.C.E.R. II to run in POST mode, set switch 9 on the 1-10 switch block to the ↓OFF (P) position. When switch 9 is set to the ↓OFF (P) position, the other switch settings on both of R.A.C.E.R. II's switch blocks have no effect, and R.A.C.E.R. II simply acts as a POST diagnostic board.
3. Turn on the computer, and carefully watch R.A.C.E.R. II's numeric display.

As the POST sequence progresses, numbers will be displayed on the numeric display, indicating that R.A.C.E.R. II is accurately reporting all POST codes it encounters. Some POST codes will be displayed for longer periods of time than others, since certain tests executed during POST check several functions and/or repeatedly test something for a given period of time.

If the system hangs during the POST (i.e., a POST code is displayed for an abnormally long period of time), it indicates



that some component or subsystem has failed. The POST code displayed should identify the area with the problem.

Depending on the BIOS used in the system, refer to the appropriate POST code list in the *POST Code Reference* section at the end of this chapter to identify the test (function) which failed.

If the system's BIOS is not included in the *POST Code Reference*, refer to the technical documentation or specifications for the system's BIOS or motherboard for a listing of codes output during the POST sequence, or contact Ultra-X Technical Support for information on the BIOS used in the system being tested.

4. If R.A.C.E.R. II's numeric display and/or LEDs do not light up (or partially light up in the case of the power supply indicators), or no POST codes are displayed when the system is powered up, check the following before you call Ultra-X for technical support:

- ◆ Make sure the power cable is attached to the computer and is plugged into the wall outlet. If the fan is not running, the power cable may be loose or not connected at all, or there may be a power short on the system board.
- ◆ Check to make sure that R.A.C.E.R. II is firmly and correctly installed in the expansion board slot (**make sure the two switch blocks are closest to the BACK of the computer**; if they're nearest the front of the computer, R.A.C.E.R. II is installed backwards and this could *destroy the board!*).
- ◆ Try installing the board in a different bus connector if the other checks listed below do not resolve the problem.

- ◆ Some critical cable within the computer, such as power supply to the system board, may not be connected or may be connected incorrectly. Check all critical cables, contacts, and wiring within the computer.
- ◆ If R.A.C.E.R. II's power supply indicators do not light up at all, are glowing intermittently, or one or more of the indicators are out, the system's power supply may be faulty. If possible, try swapping power supplies to see if that corrects the problem.
- ◆ If no POST codes appear on the numeric display, the power supply indicators are on, and none of the above situations apply, either the system's BIOS does not generate POST codes, the POST codes are not output to port 80h, or the problem is one which the BIOS POST routine cannot test or isolate.

Check the system BIOS manufacturer's specifications to see if the BIOS outputs POST codes and/or does not output POST codes to port 80h. If that's not the case, you should then set switch 9 on the 1-10 switch block to the ↑ON (R) position to run R.A.C.E.R. II's component-level diagnostics so you can isolate the problem which the POST routine failed to identify.

## POST Code Reference

This section contains listings of POST codes for the following popular BIOS products:

- ◆ AMI BIOS Rev. 2.2x
- ◆ AMI BIOS Plus
- ◆ Award 386 BIOS
- ◆ Chips & Technologies BIOS
- ◆ Faraday A-TEASE System
- ◆ IBM AT BIOS
- ◆ Phoenix BIOS
- ◆ Tandy 3000 BIOS

Refer to these listings while using R.A.C.E.R. II's POST mode to monitor POST codes generated after power-up, and to determine the cause of a failure encountered during the POST sequence.

### NOTE

If you are unsure of the type of BIOS installed in the system being tested, call the manufacturer of the motherboard or computer itself, or refer to the technical documentation that came with the system. There are many more BIOS companies and products than those listed above, and the POST codes output by your system's BIOS may be different from those listed in this section.

## AMI BIOS Rev. 2.2x

The following lists the POST error codes used for the AMI BIOS, revision 2.2x. All error codes are in hexadecimal numbers.

<u>Code</u>	<u>Description</u>
00	Processor flag test
03	Processor register test
06	System hardware initialization
09	BIOS ROM checksum initialization
0C	Page register test
0F	8254 timer test
12	Memory refresh initialization
15	8237 DMA controller test
18	8237 DMA initialization
1B	8259 interrupt controller initialization
1E	8259 interrupt controller test
21	Memory refresh test
24	Base 64K address test
27	Base 64K memory test
2A	8742 keyboard self-test
2D	MC146818 CMOS test
30	Begin first protected mode test
33	Memory sizing test
36	First protected mode test check ok
39	First protected mode test check failed
3C	CPU speed calculation
3F	Read 8742 configuration
42	Initialize interrupt vector area
45	Verify CMOS configuration
48	Test and initialize video area
4B	Unexpected interrupt test

<u>Code</u>	<u>Description</u>
4E	Begin second protected mode test
51	Verify LDT instruction
54	Verify TR instruction
57	Verify LSL instruction
5A	Verify LAR instruction
5D	Verify VERR instruction
60	Address line 20 line
63	Unexpected exception test
66	Begin third protected mode test
69	Address line test
6C	System memory test
6F	Shadow memory test
72	Extended memory test
75	Verify memory configuration
78	Display configuraton error messages
7B	Copy system BIOS to shadow memory area
81	MC46818 real time clock test
84	Keyboard test
87	Determine keyboard type
8A	Stuck key test
8D	Initialize hardware interrupt vectors
90	Math coprocessor test
93	Determine COM ports available
96	Determine LPT ports available
99	Initialize BIOS data area
9C	Fixed, floppy drive controller test
A2	Fixed disk test
A5	External ROM scan
A8	System key lock test
AB	F1 error message test
AE	System boot initialization
B1	Jump to INT boot loader

## AMI BIOS Plus

The following lists the POST error codes used for the AMI BIOS Plus. All error codes are in hexadecimal numbers.

**Manufacturing Diagnostics** — AMI also provides diagnostics functions that are useful in the manufacturing of boards. When PIN 32 on the keyboard controller is grounded, the BIOS will go through the POST (Power On Self Test) continuously. This procedure is repeated continuously until either the power is turned off or the BIOS finds a fatal error on the motherboard. In the case of a fatal error, the error beeps and message displays can be obtained in audio and video respectively. It is not necessary to connect the keyboard, video or disk controller cards to run the manufacturing diagnostics.

<u>Code</u>	<u>Description</u>
01	NMI Disabled & CPU Register Test about to start
02	CPU Register test over
03	ROM checksum ok
04	8259 Initialization ok
05	CMOS pending interrupt disabled
06	Video disabled & system timer counting ok
07	CH-2 of 8253 test ok
08	CH-2 of delta count test ok
09	CH-1 of delta count test ok
0A	CH-0 of delta count test ok
0B	Parity status cleared
0C	Refresh & system timer ok
0D	Refresh link toggling ok
0E	Refresh period on/off 50% ok
10	Confirmed refresh on & ready to start 64K memory
11	Address line test ok

<u>Code</u>	<u>Description</u>
12	64K base memory test ok
13	Interrupt vectors initialized
14	8042 keyboard controller test ok
15	CMOS read/write test ok
16	CMOS checksum/battery check ok
17	Monochrome mode set ok
18	Color mode set ok
19	Ready to view for optional video ROM
1A	Optional video ROM control ok
1B	Display memory R/W test ok
1C	Display memory R/W test for alternate display ok
1D	Video retrace check ok
1E	Global equipment byte set for video ok
1F	Mode set call for mono/color ok
20	Video test ok
21	Video display ok
22	Power on message display ok
30	Virtual mode memory test about to start
31	Virtual mode memory test started
32	Processor in virtual mode
33	Memory address line test in progress
34	Memory address line test in progress
35	Memory below 1 Mb calculated
36	Memory size computation ok
37	Memory test in progress
38	Memory initialization over below 1 Mb
39	Memory initialization over above 1 Mb
3A	Display memory size
3B	Ready to start below 1 Mb memory test
3C	Memory test below 1 Mb ok
3D	Memory test above 1 Mb ok
3E	Ready to enter to real mode (Shut-Down)
3F	Shut-Down successful and entered in real mode
40	Ready to disable gate A-20 address line
41	Gate A-20 line disabled successfully

<u>Code</u>	<u>Description</u>
42	Ready to start DMA controller test
4E	Address line test ok
4F	Processor in real mode after shut-down
50	DMA page register test ok
51	DMA unit-1 base register test ready to start
52	DMA unit-1 channel ok, ready to start CH-2
53	DMA CH-2 Base register test ok
54	Ready to test F/F latch for unit-1
55	F/F latch test both unit ok
56	DMA unit 1 & 2 programmed ok
57	8259 initialization over
58	8259 mask register check ok
59	Master 8259 mask register ok, ready to start slave
5A	Ready to check timer and keyboard inter-level
5B	Timer interrupt ok
5C	Ready to test keyboard interrupt
5D	Error! Timer/Keyboard inter-level not in proper level
5E	8259 Interrupt controller error
5F	8259 Interrupt controller test ok
70	Start of keyboard test
71	Keyboard bat test ok
72	Keyboard test ok
73	Keyboard global data intialization ok
74	Floppy setup ready to start
75	Floppy setup ok
76	Hard disk setup ready to start
77	Hard disk setup ok
79	Ready to initialize timer data area
7A	Verify CMOS battery power
7B	CMOS battery verification done
7D	Ready to analyze diagnostics test results for memory
7E	CMOS memory size update ok
7F	Ready to check optional ROM C000:0
80	Keyboard sensed to enable setup
81	Optional ROM control ok

<u>Code</u>	<u>Description</u>
82	Printer global DATA initialization ok
83	RS-233 global data initialization ok
84	80287 check/test ok
85	Ready to display soft error message
86	Ready to give control to system ROM E000:0
87	System ROM E000:0 Check over
00	Control given to INT 19, Boot loader

## Award 386 BIOS

The following lists the POST error codes used for the Award 386 BIOS. All error codes are in hexadecimal numbers.

### **NOTE**

If a failure occurs during post test 6 through FF (unless the error causes the computer to hang in the test), the system will keep outputting the post sequence to the defined post port. A normal error message will then be displayed on the screen when video is available.

<u>Code</u>	<u>Description</u>
01	Processor test #1 Processor status verification Infinite loop if test fails
02	Determine type of post test Fails if keyboard interface buffer filled with DATA Infinite loop if fails
03	Clear 8042 interface Infinite loop if tests fails
04	Reset 8042 Infinite loop if test fails
05	Get 8042 manufacturing status Read input port via keyboard controller to determine Manufacturing or normal mode operation Infinite loop if test fails
06	Initialize chips (DMA, 8259, CMOS)
07	Processor test #2
08	Initialize CMOS chip
09	Eprom checksum for 32K bytes
0A	Initialize video interface

<u>Code</u>	<u>Description</u>
0B	Test 8254 channel 0
0C	Test 8254 channel 1
0D	Test 8254 channel 2
0E	Test CMOS shutdown byte
0F	Test extended CMOS
10	Test DMA channel 0
11	Test DMA channel 1
12	Test DMA page registers
13	Test 8741 keyboard controller interface
14	Test memory refresh toggle circuits
15	Test first 64K bytes of system memory
16	Set up interrupt vector table
17	Set up video I/O operations
18	Test video memory
19	Test 8259 mask bits - channel 1
1A	Test 8259 mask bits - channel 2
1B	Test CMOS battery level
1C	Test CMOS checksum
1D	Set configuration from CMOS
1E	Size system memory & compare with CMOS
1F	Test base memory 64K to top of memory
20	Test stuck 8259's interrupt bits
21	Test stuck NMI (parity or I/O check) bits
22	Test 8259 interrupt functionality
23	Test protected mode, 8086 virtual & 8086 page mode
24	Size extended memory above 1 Mb
25	Test all memory except first 64K
26	Test protected mode exceptions
27	Set up cache control or shadow RAM
28	Set up cache controller or special 8242 key board controller
29	Reserved
2A	Initialize keyboard
2B	Initialize floppy drive & controller
2C	Detect & initialize serial ports

<u>Code</u>	<u>Description</u>
2D	Detect & initialize parallel ports
2E	Initialize hard drive & controller
2F	Detect & initialize math coprocessor
30	Reserved
31	Detected & initialize option ROMS
EE	Unexpected processor exception
CC	NMI handler shutdown
FF	Boot attempt

## Chips & Technologies BIOS

The following lists the POST error codes used by C&T BIOS. Error codes are in hexadecimal numbers.

### NOTE

These POST codes are used for both IBM and compatible PCs and IBM PS/2s; however, **not all codes are applicable to all BIOS.**

<u>Code</u>	<u>Message</u>
00H	Error in POS registers
01H	Flag register failed
02H	CPU register failed
03H	System ROM failed checksum
04H	DMA controller failed
05H	System timer failed
06H	Base 64K RAM failed address test No memory installed Improper memory configuration
07H	Base 64K failed RAM test
08H	Interrupt controller failed
09H	Hot interrupt occurred
0AH	Timer failed to generate interrupt
0BH	CPU still in protected mode
0CH	DMA page register failed
0DH	Refresh failed to occur
0EH	Keyboard controller not responding
0FH	Can not enter protected mode
10H	GDT or IDT failed
11H	LDT register failed
12H	Task register failed
13H	LSL instruction failed
14H	LAR instruction failed
15H	VERR/VERW failed

<u>Code</u>	<u>Description</u>
16H	Gate A20 failure
17H	Exception failure
18H	Shutdown during memory test
19H	Last used error code
1AH	Copyright checksum error
1BH	Shutdown during memory sizing
1CH	Chip set initialization
50H	Initialize hardware
51H	Initialize timer
52H	DMA initialization
53H	8259 initialization
54H	Initialize chip set
55H	Set up BMS configuration
56H	Entering protected mode 1st try
57H	Determine memory chips size
58H	Configure memory chip interleave
59H	Exiting protected mode 1st try
5AH	Determine system board memory size
5BH	Relocate shadow RAM
5CH	Configure EMS
5DH	Set up wait states
5EH	Retest base 64K RAM
5FH	Test shadow RAM
60H	CMOS test
61H	Video test
63H	Protected mode interrupt test
64H	Test line A20
65H	Test memory address line
66H	Memory test
67H	Extended memory test
68H	Timer interrupt test
69H	Real time clock test
6AH	Keyboard test
6BH	Coprocessor test
6CH	Serial port test
6DH	Parallel port test

<u>Code</u>	<u>Description</u>
6EH	Dual card test
6FH	Floppy drive controller test
70H	Fixed disk controller test
71H	Keylock test
72H	Pointing device test
90H	RAM setup
91H	Calculate CPU speed
92H	Check configuration
93H	BIOS initialization
94H	POD bootstrap
95H	Reset ICS
96H	POS select
97H	VGA power on diagnostics and setup
98H	Adaptor POS
A0H	Exception 0 during POD
A1H	Exception 1 during POD
A2H	Exception 2 during POD
C0H	System board memory failure
C1H	I/O channel check activated
C2H	Watchdog time out
C3H	Bus time out

## Faraday A-TEASE System

The following lists the POST error codes used for the Faraday A-TEASE system. All error codes are in hexadecimal numbers.

<u>Code</u>	<u>Description</u>
01	CPU test
02	BIOS ROM Checksum test
03	Shutdown
04	DMA Page Register test
05	Timer 8254 test
06	Start Refresh
07	Keyboard controller 8042 test
08	RAM < 128K test
09	Video setup
0A	RAM 128K to 640K test
0B	DMA #1 test
0C	DMA #2 test
0D	Interrupt controller #1 test
0E	Interrupt controller #2 test
0F	Control port test
10	Parity test
11	CMOS memory test
12	Test for manufacturing mode
13	Setup interrupt vectors
14	Keyboard test
15	Configure parallel ports
16	Configure serial ports
17	Configure memory < 640K
18	Configure memory > 1 Mb
19	Configure keyboard
1A	Configure floppy disk
1B	Configure hard disk
1C	Configure game card
1D	Configure 80287
1E	Check CMOS clock
1F	Generate CMOS checksum



<u>Code</u>	<u>Description</u>
21	Initialize PROM drivers
22	Parallel loopback test
23	Serial loopback test
24	Test CMOS clock
25	Test shutdown
26	Test memory over 1 Mb

**NOTE**

Codes 80 - FF (described below) are caused by an error in virtual mode in test 26.

<u>Code</u>	<u>Description</u>
80	Divide overflow
81	Single step
82	NMI
83	Breakpoint
84	Into detect
85	Bound error
86	Invalid opcode
87	Processor extension not available
88	Double exception
89	Processor ext segment error
8A	Invalid task state segment
8B	Segment not present
8C	Stack segment not present
8D	General protection error
8E	General protection error
8F	General protection error
90	Processor extension error
91-F2	Spurious interrupts
F3	CPU virtual test error
F3-F8	Spurious interrupts
F9	Virtual block move error
FA-FF	Spurious interrupts

## IBM AT BIOS

The following lists the POST error codes used for the IBM AT BIOS. All error codes are in hexadecimal numbers.

<u>Code</u>	<u>Description</u>
01	80286 processor test; real mode test; verify flags & registers; verify conditional jumps
02	ROM checksum test post, ROM basic, BIOS
03	CMOS shutdown byte test
04	8254 timer, all bits on
05	8254 timer, all bits off
06	8237 DMA 0 initialization
07	8237 DMA 1 initialization
08	DMA page register, 612 test
09	Storage refresh test
0A	Soft reset
0B	Reset 8042, keyboard controller
0C	Test 0b ok
0D	Write byte 0 of 8042 memory base 64K R/W test write pattern aa,55,ff,01,00
0E	Fill memory with data
0F	Get I/P buffer switch setting
10	Issue self test
11	80286 LGDT/SGDT & LIDT/SIDT
12	Protected mode registers
13	Initialize 8259 interrupt controller
14	Setup interrupt vectors
15	BIOS interrupt call vectors CMOS checksum; battery ok
16	Set data segment
17	Bad battery flag
18	CMOS dividers ready
19	Set return address byte in CMOS

<u>Code</u>	<u>Description</u>
1A	Set temporary stack protected mode test; determine memory size; verify parity.
1B	Segment address 01-0000 (2nd 64K)
1C	Set base memory size flag
1D	Segment address 10-0000 (> 640k)
1E	Set expanded memory size by CMOS
1F	Test address lines 19 - 23
20	Shutdown
21	Return 1 from shutdown; initialize video controller; test video W/R; test video enable; select alpha mode; W/R patterns
22	Enable video signal and set mode; CRT interface test; verify video enable and horizontal sync
23	Look for advanced video card
24	8259 interrupt controller test; read/write interrupt mask register; enable interrupts; mask device interrupts off
25	Test interrupt mask registers
26	Check for unexpected interrupts
27	Check converting logic
28	Check unexpected non maskable interrupts
29	Test data bus with timer 2
2D	Check 8042 for last accepted command; read/write storage test in protected mode
30	Set shutdown return 2
31	Enable protected mode
32	Test address lines 0-15
33	Check next block of 64K
34	Enable real mode; perform additional protected mode tests
35	Keyboard error test
36	Verify AA scan code
38	Check for stuck key
39	Check 8042 error

<u>Code</u>	<u>Description</u>
3A	Initialize 8042; check for optional ROM at C000-E000
3B	Check for 2K ROM blocks
3C	Check for IPL disk drive
3D	Initialize floppy drive with drive type
3E	Initialize hard file; exception interrupt routine
3F	Initialize printer
40	Enable hardware interrupt if 80287 is present
41	Check for system code at E000:0000
42	Exit to system code
43	Exit to boot loader
44	Attempt to boot from fixed disk
45	Unable to find fixed disk; jump to ROM basic
81	Build descriptor table
82	enable virtue mode
90-B6	EXEC_00 to EXEC_31 & SYS_32 to SYS_38 tests; memory test; boot loader
DD	Transmit error code to MFG_PORT
F0	Set data segment
F1	Interrupt test INT 32
F2	Exception interrupt IND 13d
F3	Check 80286 LDT/SDT and LTR/STR
F4	Check 80286 bound instruction
F5	Check push all and pop all instructions
F6	Check access right functions
F7	Check ARPL functions
F8	Check LAR instructions
F9	Check LSL instruction
FA	Low megabyte chip select function test

## Phoenix BIOS

The following lists the POST error codes and audio beep codes used for the Phoenix BIOS. All POST codes are in hexadecimal numbers.

### NOTE

A failure before system boot is output as a beep code (via the speaker) and as a POST code (via a diagnostic card, such as R.A.C.E.R. II) which identify where the problem occurred. The following table lists the Phoenix BIOS POST codes and beep codes. A normal error message is displayed on the screen when video is available.

<u>POST Code</u>	<u>Beep Code</u>	<u>Description</u>
01		80286 register test in progress
02	1-1-3	CMOS write/read test in progress or failure
03	1-1-4	BIOS ROM checksum in progress or failure
04	1-2-1	Programmable interval timer test in progress or failure
05	1-2-2	DMA initialization in progress or failure
06	1-2-3	DMA page register write/read test in progress or failure
08	1-3-1	RAM refresh verification in progress or failure
09		1st 64K RAM test in progress
0A	1-3-3	1st 64K RAM chip or data line failure - Multi-bits
0B	1-3-4	1st 64K RAM odd/even logic failure
0C	1-4-1	1st 64K RAM address line failure
0D	1-4-2	1st 64K RAM parity test in progress or failure

<u>POST Code</u>	<u>Beep Code</u>	<u>Description</u>
10	2-1-1	1st 64K RAM chip or DATA line failure - Bit 0
11	2-1-2	1st 64K RAM chip or data line failure - Bit 1
12	2-1-3	1st 64K RAM chip or data line failure - Bit 2
13	2-1-4	1st 64K RAM chip or data line failure - Bit 3
14	2-2-1	1st 64K RAM chip or data line failure - Bit 4
15	2-2-2	1st 64K RAM chip or data line failure - Bit 5
16	2-2-3	1st 64K RAM chip or data line failure - Bit 6
17	2-2-4	1st 64K RAM chip or data line failure - Bit 7
18	2-3-1	1st 64K RAM chip or data line failure - Bit 8
19	2-3-2	1st 64K RAM chip or data line failure - Bit 9
1A	2-3-3	1st 64K RAM chip or data line failure - Bit A
1B	2-3-4	1st 64K RAM chip or data line failure - Bit B
1C	2-4-1	1st 64K RAM chip or data line failure - Bit C
1D	2-4-2	1st 64K RAM chip or data line failure - Bit D
1E	2-4-3	1st 64K RAM chip or data line failure - Bit E
1F	2-4-4	1st 64K RAM chip or data line failure - Bit F
20	3-1-1	Slave DMA register test in progress or failure
21	3-1-2	Master DMA register test in progress or failure

<u>POST Code</u>	<u>Beep Code</u>	<u>Description</u>
22	3-1-3	Master interrupt mask register test in progress or failure
23	3-1-4	Slave interrupt mask register test in progress or failure
25		Interrupt vector loading in progress
27	3-2-4	Keyboard controller test in progress or failure
28		CMOS power-failure and checksum checks in progress
29		CMOS config. info. validation in progress
2B	3-3-4	Screen memory test in progress or failure
2C	3-4-1	Screen initialization in progress or failure
2D	3-4-2	Screen retrace tests in progress or failure
2E		Search for video ROM in progress
30		Screen believed operable (running with video ROM)
31		Monochromatic screen believed operable
32		40-Column color screen believed operable
33		80-Column color screen believed operable
34	4-2-1	Timer tick interrupt test in progress or failure
35	4-2-2	Shutdown test in progress or failure
36	4-2-3	Gate A-20 failure
37	4-2-4	Unexpected interrupt in protected mode
38	4-3-1	RAM test in progress or failure above 0FFFF

<u>POST Code</u>	<u>Beep Code</u>	<u>Description</u>
3A	4-3-3	Interval timer channel 2 test in progress or failure
3B	4-3-4	Time-of-day clock test in progress or failure
3C	4-4-1	Serial port test in progress or failure
3D	4-4-2	Parallel port test in progress or failure
3E	4-4-3	Math coprocessor test in progress or failure
41		System board select failure
42		Extended CMOS RAM failure

## Tandy 3000 BIOS

The following lists the POST error codes and audio beep codes used for the Tandy 3000 BIOS. All POST codes are in hexadecimal numbers.

### NOTE

The **Beep Codes** are output to the speaker if, and only if, a fatal error is detected. For example, 2-1-4 (a burst of two beeps, a single beep, a burst of four beeps) indicates a failure of bit 3 in the first 64K of RAM. Both the POST and Beep codes are only used prior to screen initialization and screen retrace verification. Once the screen has been verified, messages are written directly to the video memory at 80000 and B8000 hex.

<u>POST Code</u>	<u>Beep Code</u>	<u>Description</u>
01		80286 register test in progress or failure
02	1-1-3	CMOS write/read test in progress or failure
03	1-1-4	BIOS ROM checksum in progress or failure
04	1-2-1	Programmable interval timer test in progress or failure
05	1-2-2	DMA initialization in progress or failure
06	1-2-3	DMA page register write/read test in progress or failure
08	1-3-1	RAM refresh verification in progress or failure
09		1st 64K RAM test in progress
0A	1-3-3	1st 64K RAM chip or DATA line failure - Multi-bits
0B	1-3-4	1st 64K RAM odd/even logic failure

<u>POST Code</u>	<u>Beep Code</u>	<u>Description</u>
0C	1-4-1	1st 64K RAM address line failure
0D	1-4-2	1st 64K RAM parity failure
10	2-1-1	1st 64K RAM chip or DATA line failure - Bit 0
11	2-1-2	1st 64K RAM chip or data line failure - Bit 1
12	2-1-3	1st 64K RAM chip or data line failure - Bit 2
13	2-1-4	1st 64K RAM chip or data line failure - Bit 3
14	2-2-1	1st 64K RAM chip or data line failure - Bit 4
15	2-2-2	1st 64K RAM chip or data line failure - Bit 5
16	2-2-3	1st 64K RAM chip or data line failure - Bit 6
17	2-2-4	1st 64K RAM chip or data line failure - Bit 7
18	2-3-1	1st 64K RAM chip or data line failure - Bit 8
19	2-3-2	1st 64K RAM chip or data line failure - Bit 9
1A	2-3-3	1st 64K RAM chip or data line failure - Bit A
1B	2-3-4	1st 64K RAM chip or data line failure - Bit B
1C	2-4-1	1st 64K RAM chip or data line failure - Bit C
1D	2-4-2	1st 64K RAM chip or data line failure - Bit D
1E	2-4-3	1st 64K RAM chip or data line failure - Bit E
1F	2-4-4	1st 64K RAM chip or data line failure - Bit F
20	3-1-1	Slave DMA register test in progress or failure

<u>POST Code</u>	<u>Beep Code</u>	<u>Description</u>
21	3-1-2	Master DMA register test in progress or failure
22	3-1-3	Master interrupt mask register test in progress or failure
23	3-1-4	Slave interrupt mask register test in progress or failure
25		Interrupt vector loading in progress
27	3-2-4	Keyboard controller test in progress or failure
28		CMOS power-failure and checksum checks in progress
29		CMOS config. info. validation in progress
2B	3-3-4	Screen memory test in progress or failure
2C	3-4-1	Screen initialization in progress or failure
2D	3-4-2	Screen retrace tests in progress or failure
2E		Search for video ROM in progress
30		Screen believed operable

## Index

### A

ACC Chip Sets 6-13  
ACER 710 Computer 6-7  
AMI BIOS POST Codes 8-9, 8-11  
Award BIOS POST Codes 8-15

### B

BIOS Read-Only  
Memory Test (PC/XT) 4-1  
BIOS ROMs  
ATs and Special XTs 3-7 - 3-10  
High and Low  
Placement Reference 6-9 - 6-10  
Troubleshooting 6-2

### C

CGA Video RAM Tests  
286/386 Computers 5-10  
PC/XT Computers 4-10  
Chip Set Cross Reference  
ACC 6-13  
Chips & Technologies 6-14 - 6-15  
Faraday 6-15  
OPTI 6-16  
Suntec 6-16  
VIA FLEXSET 6-17  
VLSI Technology 6-18  
Western Digital 6-17  
Zilog 6-19  
Zymos 6-19

Chips & Technologies  
AT System Block Diagram 7-9  
BIOS POST Codes 8-18  
Chip Sets 6-14 - 6-15  
CMOS Clock Test(146818) 5-7  
COM Tests  
286/386 Computers 5-8  
PC/XT Computers 4-8 - 4-9  
Customer Support 1-9

### D

Data Log Option 1-2, 2-12 - 2-13  
Diagnostic Tests  
See Tests  
Diagnostics Mode  
Conducting Tests 3-11 - 3-15  
Definition 1-3  
Fault Trees 1-2, 3-14  
Overview 1-2  
Sample Displays 3-11 - 3-13  
Selecting Tests 2-7  
Special 286 RAM Test Modes 2-14  
Stopping Tests 3-14  
Switch 9 Setting 2-5  
System Compatibility 3-2  
Video Display Compatibility 3-3  
Dip Switches/8255 Test (PC/XT) 4-6  
DMA  
286/386 Tests 5-2 - 5-3  
PC/XT Tests 4-3  
Troubleshooting 6-3  
DTK PIM XT Motherboard 6-4 - 6-6

## E

- EGA Video Card Tests
  - 286/386 Computers 5-9
  - PC/XT Computers 4-9

## F

- Faraday
  - Chip Sets 6-15
  - POST Codes 8-21
- Fault Trees 1-2, 3-14

## H

- High and Low BIOS
  - Placement Reference 6-9

## I

- IBM
  - AT BIOS POST Codes 8-23
  - AT Compatible Block Diagram 7-4
  - AT Compatible Local and System Bus 7-6
  - AT Compatible Sub-Section Block Diagram 7-5
  - AT Model 5170-239
    - Motherboard 6-11 - 6-12
  - AT System Block Diagram 7-7
  - PC Clock Circuitry
    - Block Diagram 7-2
  - XT Block Diagram 7-3
- Installing R.A.C.E.R. II 3-5 - 3-10
- Interrupt Controller (8259) Tests
  - 286/386 Computers 5-4 - 5-5
  - PC/XT Computers 4-2

## K

- Keyboard
  - 8255 Circuit Test (PC/XT) 4-7
  - Lock Test (286/386) 5-10
  - 8042 Processor Test 5-5
  - Test for 286 Only 5-6

## L

- Lamp Test (Numeric Display) 2-5, 3-18
- LPT Tests
  - 286/386 Computers 5-9
  - PC/XT Computers 4-8

## M

- Main ADDRESS and DATA Buffers
  - Troubleshooting 6-3
- Math Coprocessor Tests
  - 286/386 Computers (80287/80387) 5-6
  - PC/XT Computers (8087) 4-7
- Memory Refresh Tests
  - 286/386 Computers 5-3
  - PC/XT Computers 4-4
- Microprocessor
  - Troubleshooting 6-3
- Microprocessor Tests
  - AT (80286/80386) 5-6
  - PC/XT (8088) 4-7
- Monochrome Video RAM Tests
  - 286/386 Computers 5-10
  - PC/XT Computers 4-9

## N

- Numeric Display 1-4, 3-15

## O

- OPTI Chip Sets 6-16

## P

- Pass/Fail Indicators 1-5, 3-15
- PC/XT Advanced Troubleshooting 6-8
- Phoenix BIOS POST Codes 8-26
- POST Codes
  - AMI BIOS Plus 8-11
  - AMI BIOS Rev. 2.2x 8-9
  - Award 386 BIOS 8-15
  - Chips & Technologies BIOS 8-18
  - Faraday A-TEASE System 8-21
  - IBM AT BIOS 8-23
  - Phoenix BIOS 8-26
  - Tandy 3000 BIOS 8-30
- POST Mode
  - Definition 1-4
  - Overview 8-1 - 8-3
  - POST Code Reference 8-8 - 8-32
  - Running R.A.C.E.R. II 8-5 - 8-7
  - Switch 9 Setting 2-5
  - System Requirements 8-4
- Power Supply
  - LEDs 1-5, 3-15
  - Troubleshooting 6-1
- Printer Port Tests
  - 286/386 Computers 5-9
  - PC/XT Computers 4-8
- Printing Test Results 1-2, 2-12 - 2-13

## R

- RAM Tests
  - CGA Video 4-10, 5-10
  - Monochrome Video 4-9, 5-10
  - Special 286 Test Mode 2-14

- System Base Memory (286/386) 5-7
- System Base Memory (PC/XT) 4-5
- Running R.A.C.E.R. II
  - Diagnostics Mode 3-11 - 3-15
  - POST Mode 8-5 - 8-7

## S

- Self Test, R.A.C.E.R. II 4-1, 5-1
- Serial Port Tests
  - 286/386 Computers 5-8
  - PC/XT Computers 4-8 - 4-9
- Speaker Test (PC/XT) 4-7
- Speed, Selecting Normal or Fast 2-6
- Suntec Chip Sets 6-16
- Switch Blocks 1-3, 2-1
  - Printing Test Results 2-12 - 2-13
  - Selecting System to Test 2-3 - 2-4
  - Selecting Tests 2-7 - 2-11
  - Selecting the Test Mode 2-5 - 2-6
  - Setting Test Speed 2-6
- Special RAM Test
  - Modes (286 only) 2-14
- System Base RAM Tests
  - 286/386 Computers 5-7
  - PC/XT Computers 4-5
- System Block Diagrams
  - 80386 System Block Diagram 7-8
  - Chips & Technologies AT
    - System Block Diagram 7-9
  - IBM AT Compatible Block Diagram 7-4
  - IBM AT Compatible Local and System Bus 7-6
  - IBM AT Compatible Sub-Section Block Diagram 7-5
  - IBM AT System Block Diagram 7-7
  - IBM PC Clock Circuitry
    - Block Diagram 7-2
  - IBM XT Block Diagram 7-3
  - VLSI AT System Block Diagram 7-10

System Bus Controller 6-3  
System Clock Generators 6-3  
System Compatibility 3-2

## T

Tandy 3000 BIOS POST Codes 8-30  
Technical Support 1-9  
Tests, 286/386  
    CGA Video RAM 5-10  
    CMOS Clock(146818) 5-7  
    80287/80387 Coprocessor 5-6  
    8237 DMA Controller 5-2 - 5-4  
    EGA Video Card 5-9  
    8259 Interrupt Controller 5-4 - 5-5  
    Keyboard (286 only) 5-6  
    Keyboard Lock 5-10  
    Memory Refresh Circuit 5-3  
    80286/80386 Microprocessor 5-6  
    Monochrome Video RAM 5-10  
    Printer Port 1 5-9  
    Printer Port 2 5-9  
    8042 Processor 5-5  
    Serial Port 1 5-8  
    Serial Port 2 5-8  
    System Base RAM 5-7  
    8254 Timer Circuit 5-2  
    Video Character Set 5-10  
    Video Switch Setting 5-6  
Tests, PC/XT  
    BIOS Read-Only Memory 4-1  
    CGA Video RAM 4-10  
    8087 Coprocessor 4-7  
    Dip Switches/8255 4-6  
    8237 DMA Circuit 4-3  
    Dynamic Memory Refresh 4-4  
    EGA Video Card 4-9  
    8259 Interrupt Controller 4-2  
    Keyboard Circuit 8255 4-7  
    8088 Microprocessor 4-7

Monochrome Video RAM 4-9  
Printer Port 1 4-8  
Printer Port 2 4-8  
Serial Port 1 4-8  
Serial Port 2 4-9  
Speaker 4-7  
System Memory (RAM) 4-5  
8253 Timer/Counter Chip 4-2  
Video Character Set 4-10  
8253 Timer/Counter Chip Test 4-2, 5-2  
Troubleshooting  
    ACER 710 Computer 6-7  
    BIOS ROMs 6-2  
    Chip Set Cross  
        Reference 6-13 - 6-19  
    Dead Systems 6-1 - 6-3  
    8237 DMA Controller 6-3  
    DTK PIM XT Motherboard 6-4 - 6-6  
    High and Low  
        BIOS Placement 6-9 - 6-10  
    IBM AT Model 5170-239  
        Motherboard 6-11 - 6-12  
    Main ADDRESS and DATA Buffers 6-3  
    Microprocessor 6-3  
    PC/XT Advanced 6-8  
    Power Supply 6-1  
    Start-up Problems 3-16 - 3-18  
    System Bus Controller 6-3  
    System Clock Generators 6-3  
    Video Problems 3-17, 6-2

## U

Ultra-X Technical Support 1-9

## V

VIA FLEXSET Chip Sets 6-17  
Video  
    Display Adapter  
        Compatibility 3-3 - 3-4  
        Troubleshooting 3-17, 6-2  
Video Tests  
    CGA RAM (286/386) 5-10  
    CGA RAM (PC/XT) 4-10  
    Character Set (286/386) 5-10  
    Character Set (PC/XT) 4-10  
    EGA (286/386) 5-9  
    EGA (PC/XT) 4-9  
    Monochrome RAM (286/386) 5-10  
    Monochrome RAM (PC/XT) 4-9  
    Switch Setting Test (286/386) 5-6  
VLSI Technology  
    AT System Block Diagram 7-10  
    Chip Sets 6-18

## W

Western Digital Chip Sets 6-17

## X

XT Computers, Special 2-3, 3-2

## Z

Zilog Chip Sets 6-19  
Zymos Chip Sets 6-19